

SERVICE DOCUMENT

7881-300 TRACK MOTION

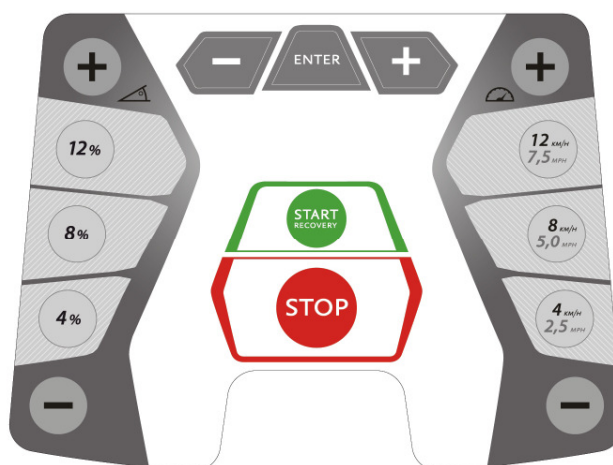

Version (13.07.2010)

Program setup flow

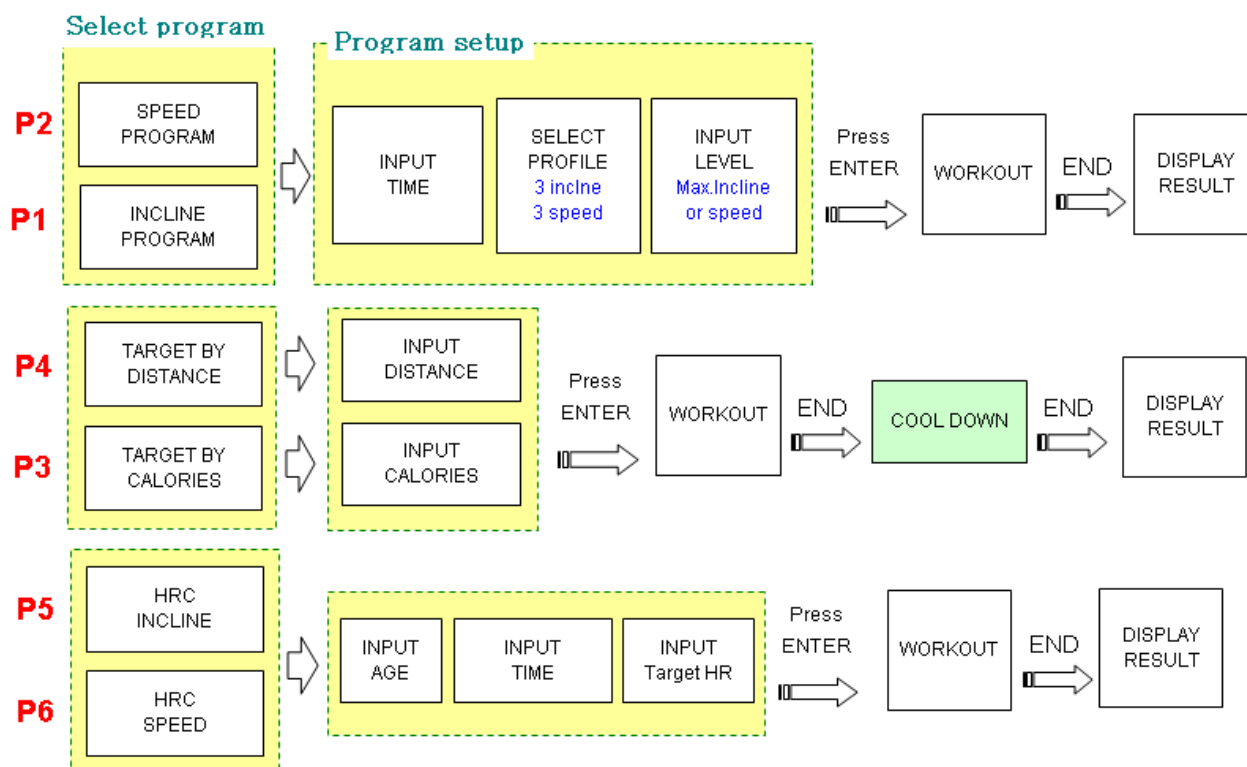

Setup mode flow

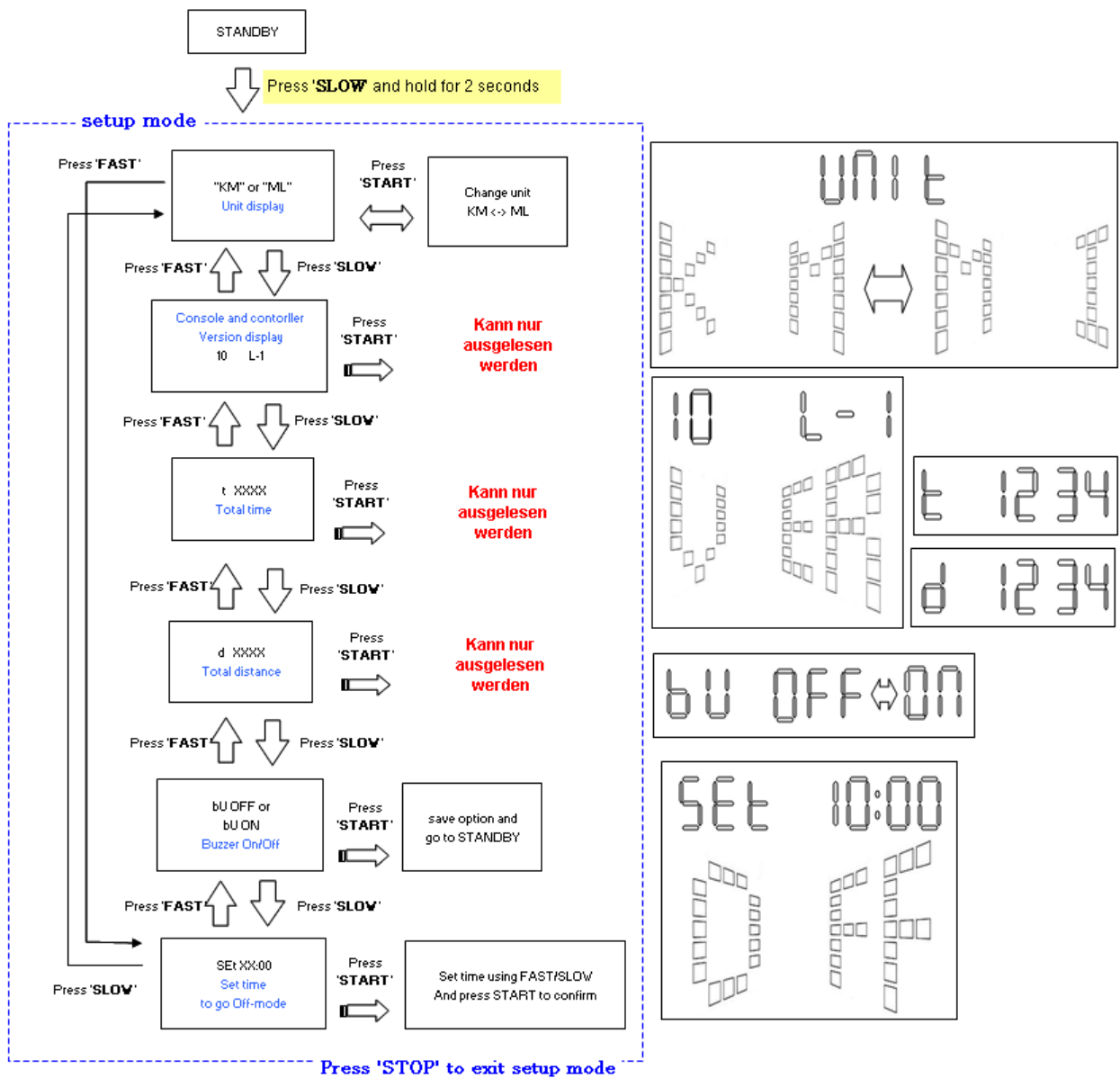

Service mode flow

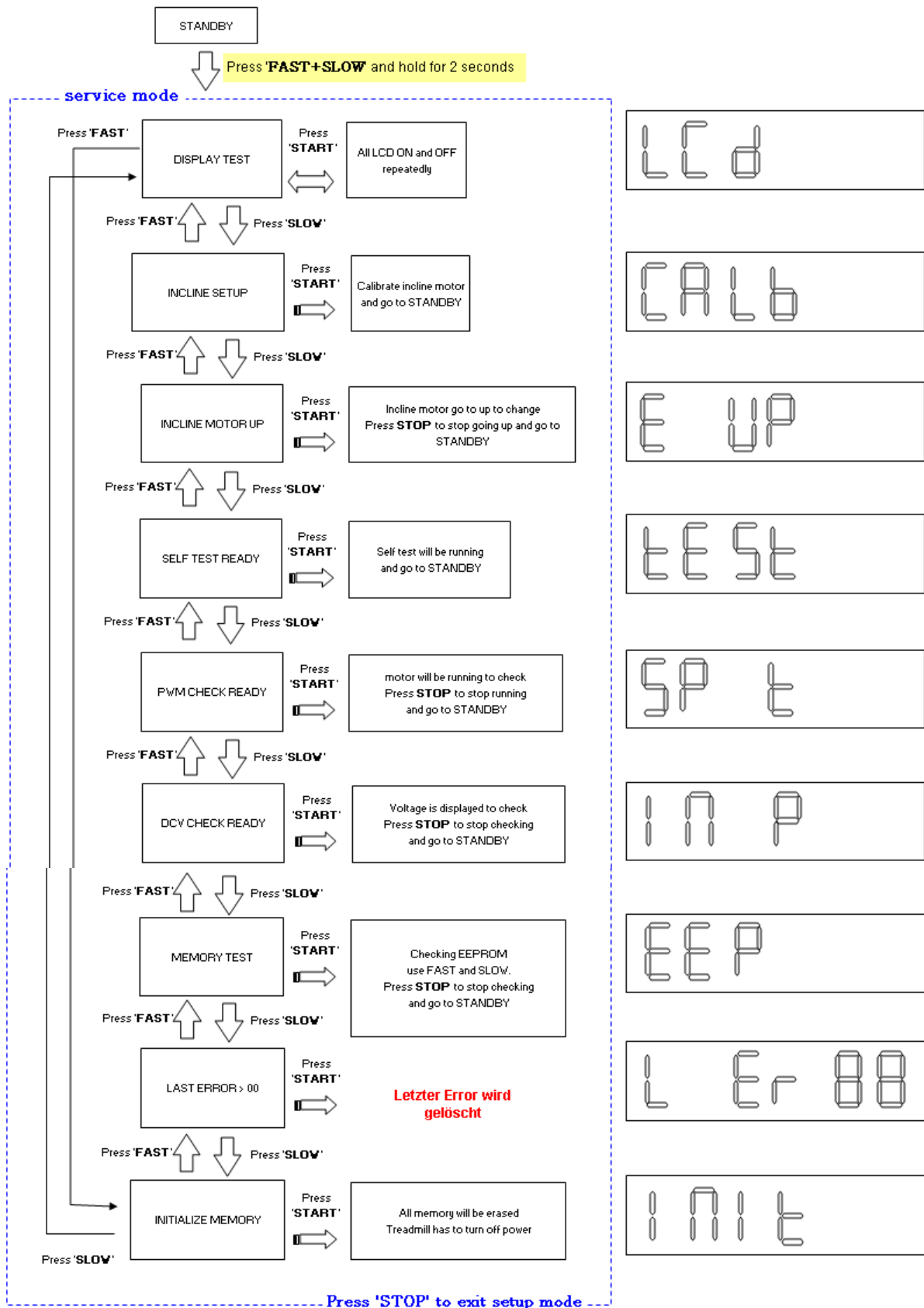

FEHLER MELDUNGEN

E r 9 1	Check speed sensor	
E r 9 2	Over speed	
E r 9 4	Check motor or IGBT	
E r 4 0	E r 4 1	Check IGBT
E r 5 1	Incline sensor cable is reversed	
E r 5 2	Incline motor is not moved	
E r 5 3	Check incline sensor cable	
E r 0 6	Check EEPROM	
E r 0 7	Check MCB version	
E r 1 0	Check communication cable	
E r 1 1	Check communication circuit	
E r 1 5	Low speed	
E r 2 2	AC inlet voltage is too high	
E r 2 3	AC inlet voltage is too low	