

VER. 1.00

Service Manual

TREADLINE

**Control
Pacer**

**Trail
Ambition**



1 FOREWORD

This Service Manual contains instructions and advice on service procedures for the Bremshey Treadline treadmills Ambition, Trail, Pacer and Control.

The primary intention of this Service Manual is to enhance the reader's knowledge of the structures of the treadmills. Notice that in case of a fault or a malfunction, the component or unit of components in question, and especially the electronic components, are not to be repaired, instead they must be replaced with a new component.

The components of the product frame and their locations with the reference and spare part numbers can best be found in the exploded parts diagrams. Replacing the components does not require special tools, but assumes a certain level of technical competence and familiarity with basic hand tools.

NB! Always when servicing the treadmill be sure that the power has been switch off and the main cable is plugged off the power board. Big capacitors on the control board might retain high voltage level even for several hours after the unit has been plugged off from the power outlet.

VERSION HISTORY			
Date	Version	Author	Change description
2006-08-7	1.00	PVI	Electronics, error codes, appendices, TOC – first public version available on the Extranet

1	FOREWORD	1
	VERSION HISTORY	1
2	ELECTRONICS	3
2.1	SERVICE MENUS	3
2.1.1	ENGINEERING MODE	3
2.1.2	TESTING MODE	4
2.1.3	LIFT MOTOR CALIBRATION	5
3	ERROR TEXTS	7
	E1	7
	E6	7
	E7	8
4	APPENDICES	9
1.	LOWER BOARD AND CONNECTOR LOCATIONS	9
2.	TECHNICAL DATA	9
3.	TROUBLESHOOTING	10
4.	SPARE PART DIAGRAMS	11

2 ELECTRONICS

The main electrical components are user interface (B02), power board (B48), motor (B18), lift motor (B28) speed sensor (B30), and power cable (B27).

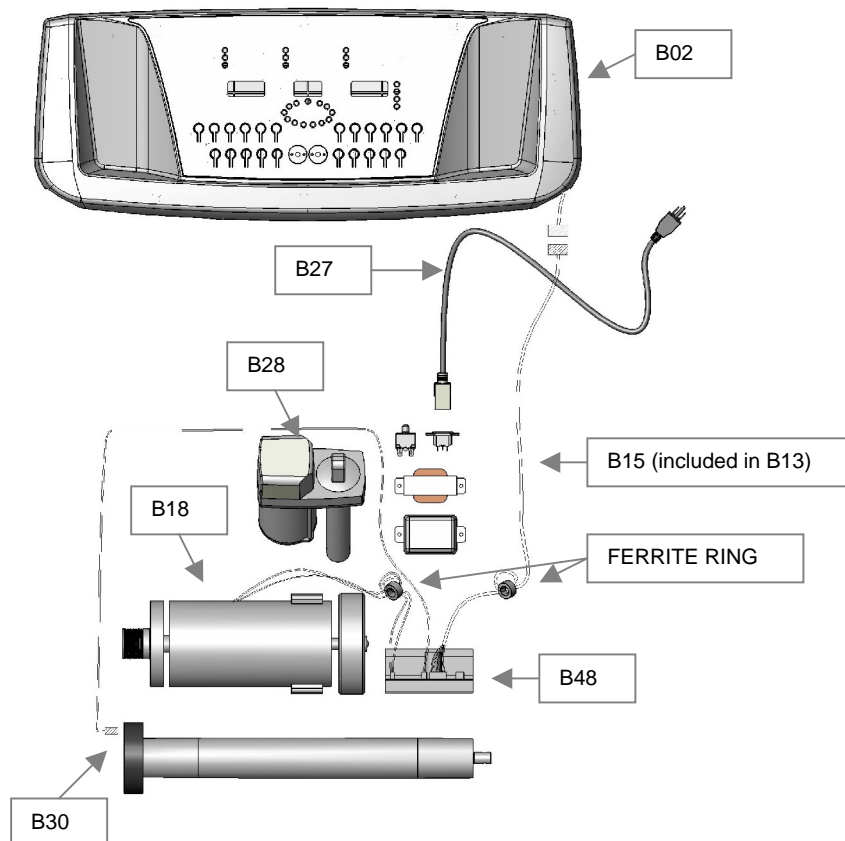

Figure 1 Electrical components and their connections (numbering refers to spare part diagram)

2.1 SERVICE MENUS

2.1.1 Engineering Mode

1. Enter the engineering mode after switching the treadmill POWER ON by pushing first 'SELECT' and then 'ENTER' and hold buttons pressed simultaneously
2. The SPEED window shows the treadmill software version number, TIME window shows the software design year and DISTANCE window shows the design date in "MM.DD" format
3. Press 'ENTER' to show LDU version number (Display control software)

4. Press 'ENTER' to show ISP version number
5. Press 'ENTER' to enter **KM/MILE switch mode**, 1 for KM, 0 for MILE
 - Switch between the KM or MILE setting by pressing SPEED +/- or ELEVATION +/-
6. Press 'ENTER' to show **total distance**
7. Press 'ENTER' to show **total usage hours**
8. Press 'ENTER' to return to the normal mode

2.1.2 Testing Mode

1. Enter the testing mode after switching the treadmill POWER ON by pushing first 'SELECT' and then 'SPEED DOWN' and hold buttons pressed simultaneously
2. LED scanning mode for verifying display functionality
3. Press 'ENTER' to scan DATA LINES to verify display functionality
4. Press 'ENTER' to scan SACN LINES to verify display functionality
5. Press 'ENTER' to scan LED's to verify display functionality
6. After pressing 'ENTER' the TIME window shows "test" and the keypad functionality can be tested (the value displayed changes when a button is being pressed)
7. Press 'ENTER' to enter IO mode (TIME display shows lift motor potentiometer value, SPEED reads speed from speed sensor and DISTANCE shows heart rate pulse) See picture below.



- Press 'START' to test lower board relay (a "click" sound) and then press 'ELEVATION UP' for 2 seconds to increase the elevation to 8%. Press 'ELEVATION DOWN' to decrease the elevation to minimum percentage 0%
- Press 'SPEED UP' to increase speed value and 'SPEED DOWN' to decrease speed value.

Press 'ENTER' to repeat above test or 'SELECT' and ' SPEED DOWN' buttons simultaneously to return to the normal mode

2.1.3 Lift motor calibration

The lift motor calibration is done manually by following the following steps:

1. Drive the lift motor to 0% from user interface (inclination display must be 0%)
2. Switch off the treadmill and unplug the power cable
3. Remove motor cover
4. Fold up the running deck
5. Loosen two screws (A) attaching the lift motor nut (B) to the incline frame (Figure 2)
6. Adjust the lift motor nut (B) so that there is 9 mm gap between the upper end of the nut and the lift motor frame (Figure 2)
7. Tighten the screws (A) and verify correct elevation by measuring (Figure 3)

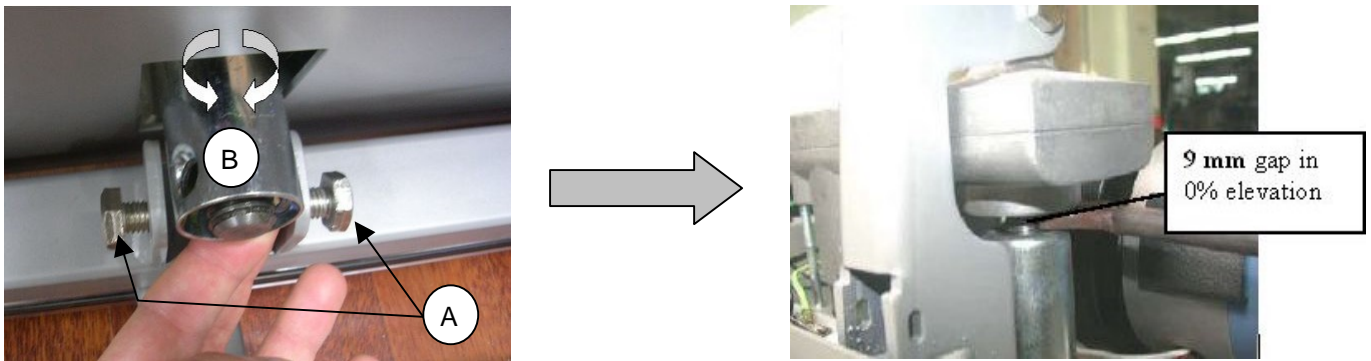

Figure 2 Adjusting lift motor to 0% position

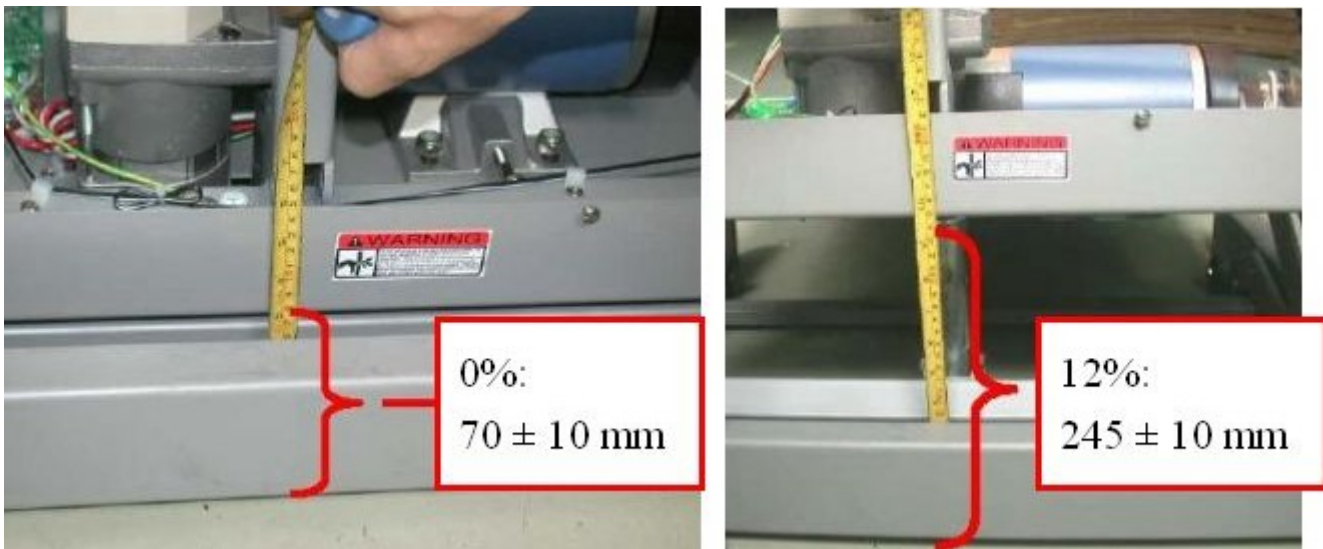

Figure 3 Measuring correct lift motor positions

Lift motor calibration is needed if any of the following has taken place:

- The lift motor has been removed from the frame
- The actual and the displayed elevation angle doesn't match

Table 1 Lift motor potentiometer value table

Elevation	Lift motor I/O
0 %	90 ± 30 (1,1 ± 0,1 kΩ)
1 %	170 ± 30
2 %	240 ± 30
3 %	320 ± 30
4 %	400 ± 30
5 %	490 ± 30
6 %	590 ± 30
7 %	700 ± 30
8 %	810 ± 30
9 %	940 ± 30
10 %	1090 ± 30
11 %	1240 ± 30
12 %	1420 ± 30 (8,54 ± 0,1 kΩ)

The values in the Table 1 are reference information for troubleshooting only. Resistance is measured from black and white wires (see picture below)

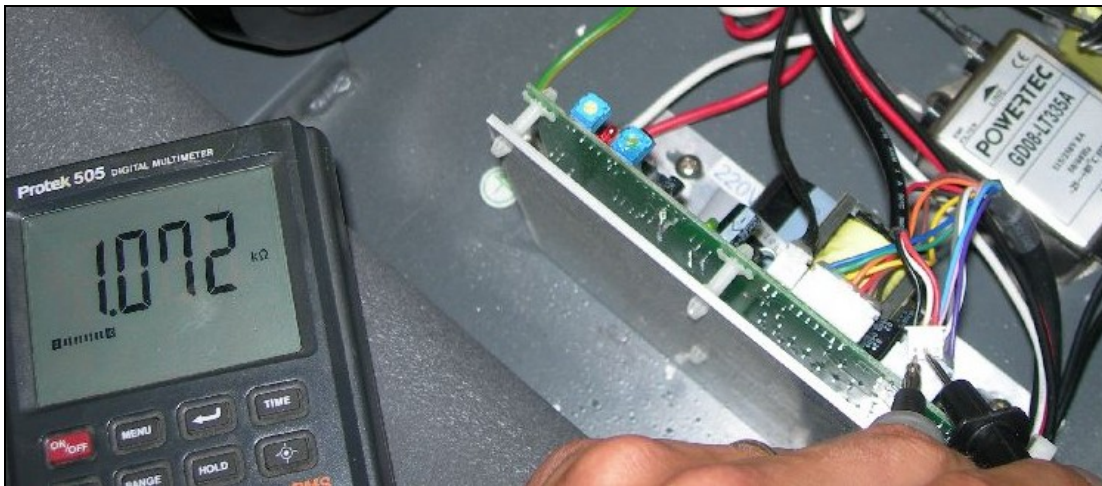

Figure 4 The lift motor potentiometer resistance at 0% inclination (measurement between black and white wire)

3 ERROR TEXTS

To facilitate the maintenance, error codes on display refer to internally found malfunctions; error codes as such aren't malfunctions, they merely point to observed problem. As a general rule, when a source of malfunction is located, it should not be repaired, but instead replaced with a new component. Error texts can be removed from the display by disconnecting the treadmill power cable for about 10 seconds.

When an error text occurs, the first thing to do, if not any obvious visible reasons found, is to try to repeat it after being switched off and on again.

E1

Instruction in the owner's manual:

"Speed sensor error. Unplug the electrical cord from the wall outlet and from the treadmill, wait 1 minute and turn the power switch on again. If treadmill recovers to normal operation, you may continue to use the treadmill. Otherwise, call the dealer for service."

The error will appear if the upper board can not receive pulses from the speed sensor for 10 seconds.

Possible reasons:

- Speed sensor not properly assembled, the distance between the magnet and the speed sensor should be less than 3mm.
- Speed sensor cable disconnected
- Meter cable has a poor connection at some point
- Magnet missing from the front roller pulley
- Front roller not rotating at all due to loose drive belt

Check the distance between the speed sensor and the flywheel and ensure that the speed sensor is properly attached to the motor frame. Check also speed sensor connections.

Error can be reset also by re-inserting the safety key.

E6

Instruction in the owner's manual:

"Lift motor error. Unplug the electrical cord from the wall outlet and from the treadmill, wait 1 minute and turn the power switch on again. If treadmill recovers to normal operation, you may continue to use the treadmill. Otherwise, call the dealer for service."

The error message appears when voltage is being supplied to the lift motor but it doesn't move.

Possible reasons:

- Lift motor power cable disconnected
- Lift motor electronically damaged preventing the movement

Error can be reset only by disconnecting the power cable.

E7

Instruction in the owner's manual:

"Lift motor error. Unplug the electrical cord from the wall outlet and from the treadmill, wait 1 minute and turn the power switch on again. If treadmill recovers to normal operation, you may continue to use the treadmill. Otherwise, call the dealer for service."

The values the lift motor potentiometer is sending are not within the preset limits. Check the potentiometer I/O value from the service menu (Chapter 2.1.2) and compare it to minimum and maximum reference values in chapter 2.1.3. The potentiometer value is also displayed on the user interface when "error 7" appears.

If the readout from the potentiometer is 1 the software is not picking any signal from the potentiometer
Possible reasons:

- Lift motor rotation sensor (potentiometer) cable disconnected
- Lift motor rotation sensor has poor internal contact thus providing incorrect values
- The second connection cable between user interface and lower board disconnected
- The potentiometer has lost its calibration and rotated to minimum

If the readout from the potentiometer has lost its calibration setting and it differs from reference values adjust potentiometer (Figure 5) to obtain correct value.



Figure 5 Lift motor potentiometer adjustment and how it affects on readout value

If the potentiometer has lost its position it can be lifted up after removing two attachment screws. Turn the potentiometer shaft to obtain correct setting and place the potentiometer back to the lift motor. To ensure that potentiometer maintains correct calibration setting a small amount of glue should be added to shaft before inserting it back to its counterpart.

Error can be reset also by re-inserting the safety key.

4 APPENDICES

1. LOWER BOARD AND CONNECTOR LOCATIONS

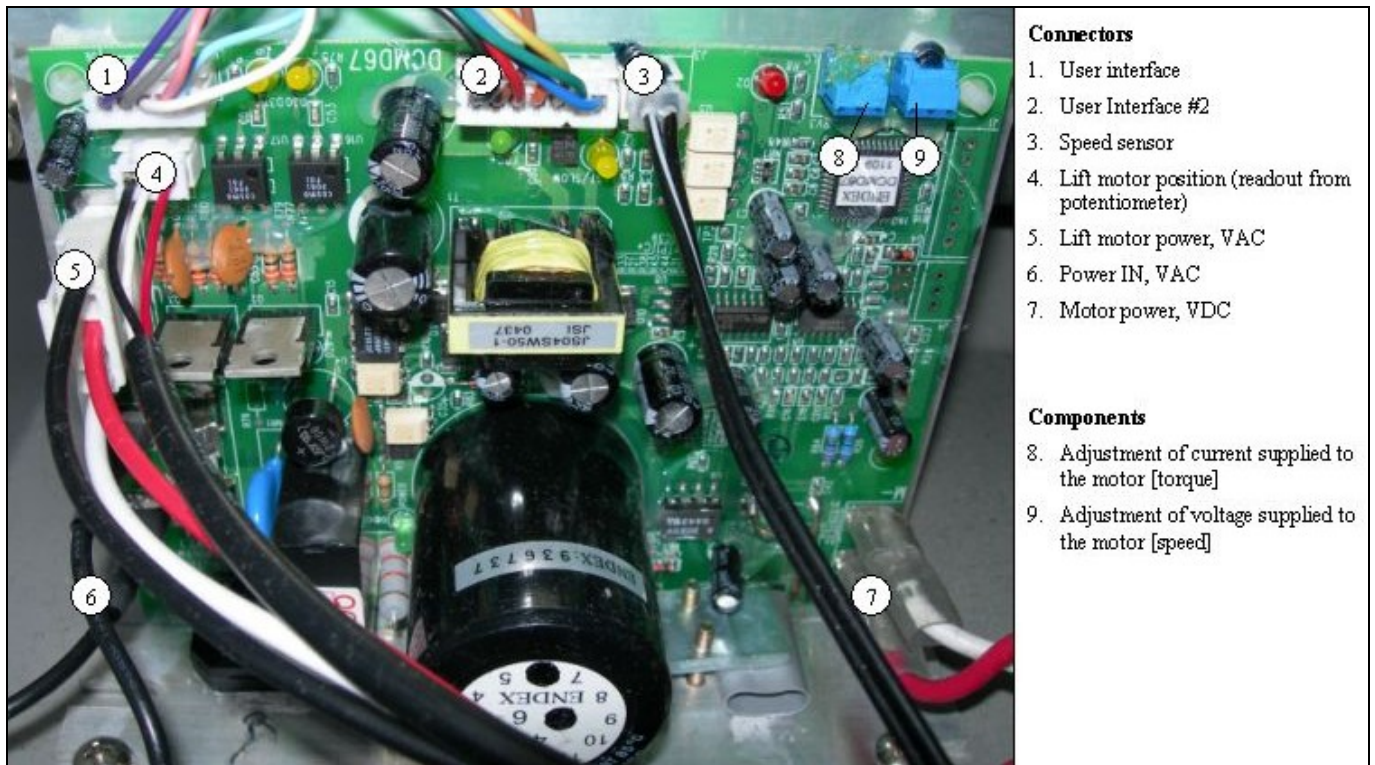

Connectors

1. User interface
2. User Interface #2
3. Speed sensor
4. Lift motor position (readout from potentiometer)
5. Lift motor power, VAC
6. Power IN, VAC
7. Motor power, VDC

Components

8. Adjustment of current supplied to the motor [torque]
9. Adjustment of voltage supplied to the motor [speed]

Figure 6 Lower board connectors and components

2. TECHNICAL DATA

Control

- Length (storage position)190 cm (82 cm)
- Height (storage position)144 cm (186 cm)
- Width 86 cm
- Weight 99 kg
- Running surface 51 x 141 cm
- Speed 0.8-20.0 km/h
- Incline range 0-12 %
- Motor..... 3.0 HP

Pacer

- Length (storage position)190 cm (82 cm)
- Height (storage position)144 cm (186 cm)
- Width 86 cm
- Weight 99 kg
- Running surface 51 x 141 cm

Speed	0.8-20.0 km/h
Incline range	0-12 %
Motor.....	3.0 HP

Trail

Length (storage position)	183 cm (82 cm)
Height (storage position)	144 cm (186 cm)
Width	82 cm
Weight	94 kg
Running surface	48 x 134 cm
Speed	0.8-18 km/h
Incline range	0-12 %
Motor.....	2.5 HP

Ambition

Length (storage position)	NA
Height (storage position)	NA
Width	NA
Weight	NA
Running surface	51 x 135 cm / 20" x 53"
Speed	0.8-16 km/h
Incline range	0-10 %
Motor.....	2.5 HP

The Control, Pacer, Trail and Ambition treadmills meet the requirements of the EU's EMC Directives on electromagnetic compatibility (89/336/EEC) and electrical equipment designed for use within certain voltage limits (73/23/EEC). This product therefore carries the CE label.

The Control, Pacer, Trail and Ambition treadmills meet EN precision and safety standards (EN-957).

3. TROUBLESHOOTING

- Treadmill is making knocking noise
 - The best way to start finding the root cause of the problem is to listen to the frequency of the noise. For example, the running belt seam overlaps a roller twice per revolution, should this be the frequency of the noise, the belt needs to be adjusted or replaced. If the noise has significantly higher frequency it is likely to be caused by a damaged front or rear roller bearing.
 - Adjust the rear foot to make the treadmill deck even with the floor
- Heart rate readings are inaccurate
 - The motor wires need to be wrapped through a ferrite ring and twisted around each other in order to prevent possible heart rate reading interference
 - Home appliances, e.g. TV and mobile phone, and electric network can generate interference. Try using equipment in different environment
- Circuit breaker (10A) trips repeatedly
 - Check that the treadmill is running mechanically free
 - Check belt lubrication

- If the wall outlet voltage is lower than normal the required current is higher and might cause the breaker to trip
- Static electricity
 - Lubricate deck according to instructions in owner's manual
 - Eliminate static electricity generators; user should not use nylon clothing and/or should try another pair of different type of training shoes
 - Ensure that the frame grounding wires are contacting steel by removing possible paint between the wire connector and frame (see picture)

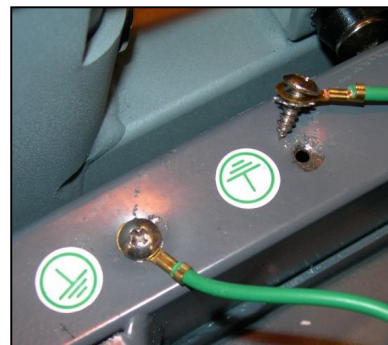
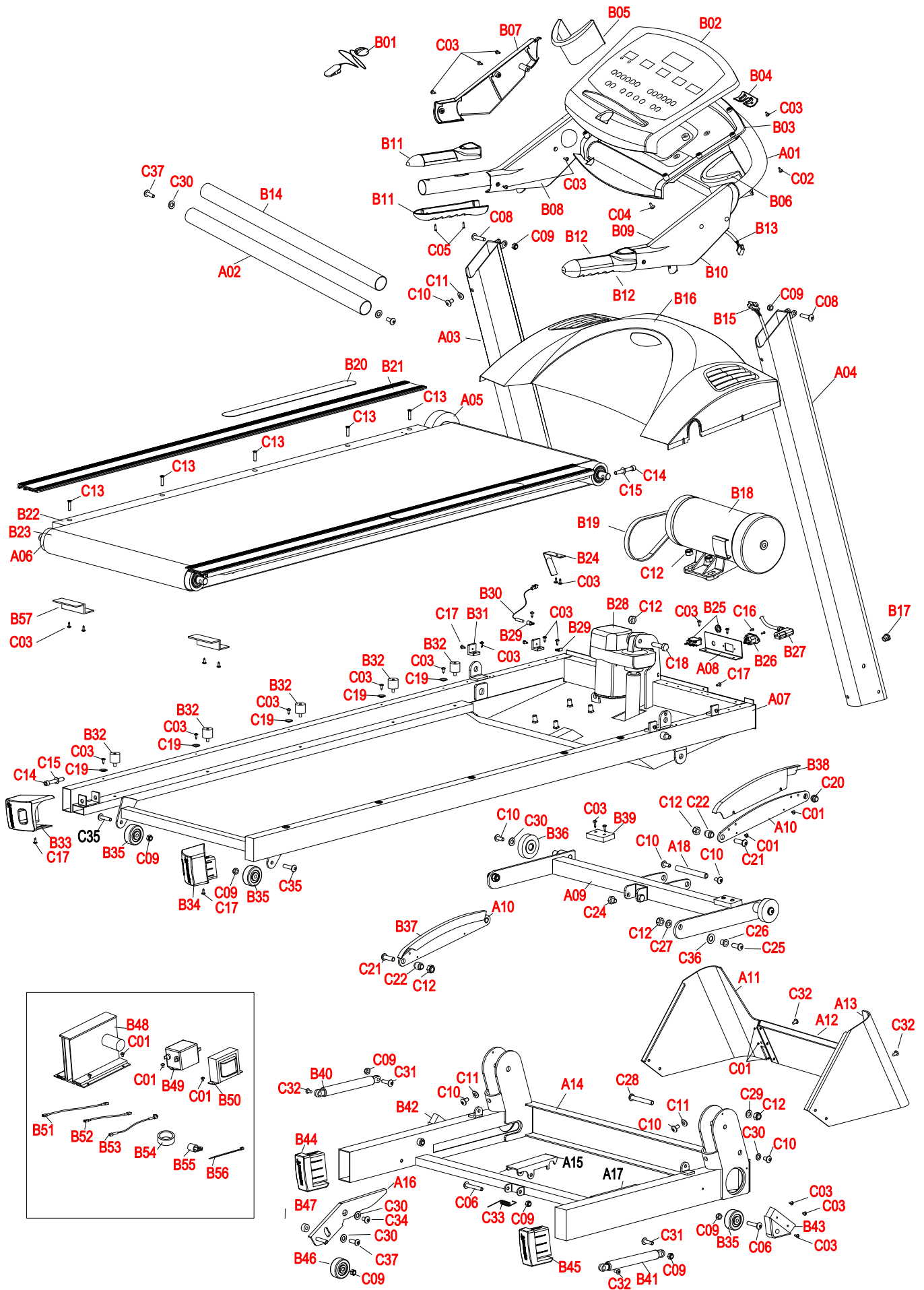

Figure 7 Proper grounding eliminates static electricity

4. SPARE PART DIAGRAMS

Please refer to the next page.

Control (445519)



Control

Item	Part No	Description	Unit	Item	Part No	Description	Unit
A01	103 4088 20	Console base	1	B40	163 4011	Gas spring	2
A02	203 4083 20	Horizontal bar (incl. B14)	1	B42	533 4143 20	Front frame end cap LH	1
A03	203 4078 20	Handlebar, LH	1	B43	533 4144 20	Front frame end cap RH	1
A04	203 4079 20	Handlebar, RH	1	B44	533 4145 20	Front support end cap LH	1
A05	523 4066	Front roller	1	B45	533 4146 20	Front support end cap RH	1
A06	523 4067	Rear roller	1	B46	533 4127	Wheel	2
A07	103 4085 20	Frame	1	B47	653 4064	Plastic washer	2
A08	503 4089 20	Switch bracket	1	B48	403 4187	Power board, 230V	1
A09	103 4087 20	Incline structure frame	1	-	403 4188	Power board, 110V	1
A10	503 4090 20	Incline bracket	2	B49	403 4174	Filter, EUR	1
A11	433 4072 20	Front frame cover (incl.A12,A13)	1	B50	403 4175	Transformer, EUR	1
A14	103 4086 20	Front support frame	1	B51	403 4176	Wire set (incl. B51,B52, B53)	1
A15	373 4014 20	Locking lever	1	B54	403 4181	Ferrite	2
A16	533 4134 20	Wheel bracket LH	1	B55	503 4095	Wire holder	2
A17	533 4135 20	Wheel bracket RH	1	B57	433 4047	Z-plate	2
A18	343 4022 20	Locking lever shaft	1	C01	M4x6 DIN 7500 C	Screw	18
B01	403 4182	Safety key	1	C02	KB 40x8 WN 1442	Screw	5
B02	233 4052 20	User interface, (incl. B03)	1	C03	4,2x12 DIN 7981	Screw (*4 pcs)	46
B03	173 4142 20	Lower cover	1	C04	M5x12 DIN 7985	Screw	4
B04	173 4143 20	Cover	1	C05	3,5x16 DIN 7981	Screw	4
B05	173 4144 20	Bottle holder, LH	1	C06	M8x55 ISO 7380	Hexagon screw	3
B06	173 4145 20	Bottle holder, RH	1	C08	M8x35 ISO 7380	Hexagon screw	2
B07	173 4146 20	Handlebar cover, LH (incl. B08)	1	C09	M8 DIN 985	Locking nut	11
B09	173 4148 20	Handlebar cover, RH (incl. B10)	1	C10	M8x20 ISO 7380	Hexagon screw (*6 pcs)	10
B11	173 4150 20	Hand pulse, LH	1	C11	653 4066	Washer (*4 pcs)	4
B12	173 4151 20	Hand pulse, RH	1	C12	M10 DIN 985	Nylock nut	11
B13	403 4170	Wire set (incl. B15)	1	C13	M6x25 DIN 7991	Countersunk head screw	10
B14	213 4028 20	Handle grip	1	C14	M8x55 DIN 912	Hexagon socket cap screw	3
B16	173 4153 20	Motor cover	1	C15	M8 DIN 125	Washer	3
B17	533 4140	Through-leading rubber	1	C16	2,9x10 DIN 7982	Screw	2
B18	813 4041	Motor, 230V	1	C17	4,2x12 DIN 7981	Screw	8
-	813 4042	Motor, 110V	1	C18	M10x40 DIN 931	Screw	1
B19	443 4056	Drive belt	1	C19	653 4067	Washer	10
B20	433 4069 20	Anti-slip mat,pair	1	C20	523 4064	Fixing tube	2
B21	433 4074 20	Side landing	2	C21	M10x32 ISO 7380	Hexagon screw	2
B22	433 4068	Running deck	1	C22	523 4065	Fixing tube	2
B23	443 4059 20	Running belt	1	C24	M10x12 ISO 4032	Hexagon screw	2
B24	693 4008	Belt guide	2	C25	M10x25 ISO 7380	Hexagon screw	2
B25	403 4185	Overcurrent protector	1	C26	523 4064	Fixing tube	2
B26	403 4186	Power socket	1	C27	M10 DIN 125	Washer	2
B27	403 4134 EU	Power cable	1	C28	M10x70 DIN 912	Screw	2
-	403 4134 USA	Power cable	1	C29	M10 DIN 6798A	Washer	2
-	403 4134 GB	Power cable	1	C30	M8 DIN 125	Washer (*2 pcs)	10
-	403 4134 ISR	Power cable	1	C31	M8x28 ISO 7380	Hexagon screw	2
-	403 4134 SUI	Power cable	1	C32	M6x12 DIN 7985	Screw (*2 pcs)	4
-	403 4168 AUS	Power cable	1	C33	643 4010	Spring	1
B28	813 4038	Lift motor	1	C34	M8x15 ISO 7380	Hexagon screw	4
B29	503 4094	Wire holder	3	C35	M8x40 ISO 7380	Hexagon screw	4
B30	403 4169	Speed sensor	1	C36	653 4068	Plastic washer	2
B31	503 4091	Motor cover bracket	4	C37	M8x25 DIN 912	Hexagon socket cap screw	4
B32	533 4133	Rubber bumper	8	-	423 4154 20	Label set	1
B33	533 4141 20	Rear end cap, LH	1	-	553 4029 20	Assembly kit (incl. *)	1
B34	533 4142 20	Rear end cap, RH	1	*	556 032 00	Allen key, 6mm	1
B35	533 4128	Wheel	4	*	553 101 88	Screw wrench	1
B36	533 4129	Wheel	2	-	583 4038 20	Owner's manual	1
B37	173 4128 20	Incline bracket cover, LH	1				
B38	173 4127 20	Incline bracket cover, RH	1				
B39	683 4017	Bumper	2				

Pacer

Item	Part No	Description	Unit
A01	103 4088 20	Console base	1
A02	203 4083 20	Horizontal bar (incl. B14)	1
A03	203 4078 20	Handlebar, LH	1
A04	203 4079 20	Handlebar, RH	1
A05	523 4066	Front roller	1
A06	523 4067	Rear roller	1
A07	103 4085 20	Frame	1
A08	503 4089 20	Switch bracket	1
A09	103 4087 20	Incline structure frame	1
A10	503 4090 20	Incline bracket	2
A11	433 4072 20	Front frame cover (incl.A12,A13)	1
A14	103 4086 20	Front support frame	1
A15	373 4014 20	Locking lever	1
A16	533 4134 20	Wheel bracket LH	1
A17	533 4135 20	Wheel bracket RH	1
A18	343 4022 20	Locking lever shaft	1
B01	403 4182	Safety key	1
B02	233 4052 20	User interface, (incl. B03)	1
B03	173 4142 20	Lower cover	1
B04	173 4143 20	Cover	1
B05	173 4144 20	Bottle holder, LH	1
B06	173 4145 20	Bottle holder, RH	1
B07	173 4146 20	Handlebar cover, LH (incl. B08)	1
B09	173 4148 20	Handlebar cover, RH (incl. B10)	1
B11	173 4150 20	Hand pulse, LH	1
B12	173 4151 20	Hand pulse, RH	1
B13	403 4170	Wire set (incl. B15)	1
B14	213 4028 20	Handle grip	1
B16	173 4153 20	Motor cover	1
B17	533 4140	Through-leading rubber	1
B18	813 4041	Motor, 230V	1
	- 813 4042	Motor, 110V	1
B19	443 4056	Drive belt	1
B20	433 4069 20	Anti-slip mat,pair	1
B21	433 4074 20	Side landing	2
B22	433 4068	Running deck	1
B23	443 4057 20	Running belt	1
B24	693 4008	Belt guide	2
B25	403 4185	Overcurrent protector	1
B26	403 4186	Power socket	1
B27	403 4134 EU	Power cable	1
	- 403 4134 USA	Power cable	1
	- 403 4134 GB	Power cable	1
	- 403 4134 ISR	Power cable	1
	- 403 4134 SUI	Power cable	1
	- 403 4168 AUS	Power cable	1
B28	813 4038	Lift motor	1
B29	503 4094	Wire holder	3
B30	403 4169	Speed sensor	1
B31	503 4091	Motor cover bracket	4
B32	533 4133	Rubber bumper	8
B33	533 4141 20	Rear end cap, LH	1
B34	533 4142 20	Rear end cap, RH	1
B35	533 4128	Wheel	4
B36	533 4129	Wheel	2
B37	173 4128 20	Incline bracket cover, LH	1
B38	173 4127 20	Incline bracket cover, RH	1
B39	683 4017	Bumper	2

Item	Part No	Description	Unit
B40	163 4011	Gas spring	2
B42	533 4143 20	Front frame end cap LH	1
B43	533 4144 20	Front frame end cap RH	1
B44	533 4145 20	Front support end cap LH	1
B45	533 4146 20	Front support end cap RH	1
B46	533 4127	Wheel	2
B47	653 4064	Plastic washer	2
B48	403 4187	Power board, 230V	1
	- 403 4188	Power board, 110V	1
B49	403 4174	Filter, EUR	1
B50	403 4175	Transformer, EUR	1
B51	403 4176	Wire set (incl. B51,B52, B53)	1
B54	403 4181	Ferrite	2
B55	503 4095	Wire holder	2
B57	433 4047	Z-plate	2
C01	M4x6 DIN 7500 C	Screw	18
C02	KB 40x8 WN 1442	Screw	5
C03	4,2x12 DIN 7981	Screw (*4 pcs)	46
C04	M5x12 DIN 7985	Screw	4
C05	3,5x16 DIN 7981	Screw	4
C06	M8x55 ISO 7380	Hexagon screw	3
C08	M8x35 ISO 7380	Hexagon screw	2
C09	M8 DIN 985	Locking nut	11
C10	M8x20 ISO 7380	Hexagon screw (*6 pcs)	10
C11	653 4066	Washer (*4 pcs)	4
C12	M10 DIN 985	Nylock nut	11
C13	M6x25 DIN 7991	Countersunk head screw	10
C14	M8x55 DIN 912	Hexagon socket cap screw	3
C15	M8 DIN 125	Washer	3
C16	2,9x10 DIN 7982	Screw	2
C17	4,2x12 DIN 7981	Screw	8
C18	M10x40 DIN 931	Screw	1
C19	653 4067	Washer	10
C20	523 4064	Fixing tube	2
C21	M10x32 ISO 7380	Hexagon screw	2
C22	523 4065	Fixing tube	2
C24	M10x12 ISO 4032	Hexagon screw	2
C25	M10x25 ISO 7380	Hexagon screw	2
C26	523 4064	Fixing tube	2
C27	M10 DIN 125	Washer	2
C28	M10x70 DIN 912	Screw	2
C29	M10 DIN 6798A	Washer	2
C30	M8 DIN 125	Washer (*2 pcs)	10
C31	M8x28 ISO 7380	Hexagon screw	2
C32	M6x12 DIN 7985	Screw (*2 pcs)	4
C33	643 4010	Spring	1
C34	M8x15 ISO 7380	Hexagon screw	4
C35	M8x40 ISO 7380	Hexagon screw	4
C36	653 4068	Plastic washer	2
C37	M8x25 DIN 912	Hexagon socket cap screw	4
	- 423 4153 20	Label set	1
	- 553 4029 20	Assembly kit (incl. *)	1
	* 556 032 00	Allen key, 6mm	1
	* 553 101 88	Screw wrench	1
	- 583 4036 20	Owner's manual	1

Trail

Item	Part No	Description	Unit	Item	Part No	Description	Unit
A01	103 4089 20	Console base	1	B40	163 4011	Gas spring	2
A02	203 4084 20	Horizontal bar (incl. B14)	1	B42	533 4143 20	Front frame end cap LH	1
A03	203 4078 20	Handlebar, LH	1	B43	533 4144 20	Front frame end cap RH	1
A04	203 4079 20	Handlebar, RH	1	B44	533 4145 20	Front support end cap LH	1
A05	523 4062	Front roller	1	B45	533 4146 20	Front support end cap RH	1
A06	523 4063	Rear roller	1	B46	533 4127	Wheel	2
A07	103 4077 20	Frame	1	B47	653 4064	Plastic washer	2
A08	503 4089 20	Switch bracket	1	B48	403 4183	Power board, 230V	1
A09	103 4079 20	Incline structure frame	1	-	403 4184	Power board, 110V	1
A10	503 4090 20	Incline bracket	2	B49	403 4174	Filter, EUR	1
A11	433 4071 20	Front frame cover (incl.A12,A13)	1	B50	403 4175	Transformer, EUR	1
A14	103 4078 20	Front support frame	1	B51	403 4176	Wire set (incl. B51,B52, B53)	1
A15	373 4014 20	Locking lever	1	B54	403 4181	Ferrite	2
A16	533 4134 20	Wheel bracket LH	1	B55	503 4095	Wire holder	2
A17	533 4135 20	Wheel bracket RH	1	B57	433 4047	Z-plate	2
A18	343 4022 20	Locking lever shaft	1	C01	M4x6 DIN 7500 C	Screw	18
B01	403 4182	Safety key	1	C02	KB 40x8 WN 1442	Screw	5
B02	233 4051 20	User interface, (incl. B03)	1	C03	4,2x12 DIN 7981	Screw (*4 pcs)	45
B03	173 4142 20	Lower cover	1	C04	M5x12 DIN 7985	Screw	4
B04	173 4143 20	Cover	1	C05	3,5x16 DIN 7981	Screw	4
B05	173 4144 20	Bottle holder, LH	1	C06	M8x55 ISO 7380	Hexagon screw	3
B06	173 4145 20	Bottle holder, RH	1	C08	M8x35 ISO 7380	Hexagon screw	2
B07	173 4146 20	Handlebar cover, LH (incl. B08)	1	C09	M8 DIN 985	Locking nut	11
B09	173 4148 20	Handlebar cover, RH (incl. B10)	1	C10	M8x20 ISO 7380	Hexagon screw (*6 pcs)	10
B11	173 4150 20	Hand pulse, LH	1	C11	653 4066	Washer (*4 pcs)	4
B12	173 4151 20	Hand pulse, RH	1	C12	M10 DIN 985	Nylock nut	11
B13	403 4170	Wire set (incl. B15)	1	C13	M6x25 DIN 7991	Countersunk head screw	10
B14	213 4027 20	Handle grip	1	C14	M8x55 DIN 912	Hexagon socket cap screw	3
B16	173 4152 20	Motor cover	1	C15	M8 DIN 125	Washer	3
B17	533 4140	Through-leading rubber	1	C16	2,9x10 DIN 7982	Screw	2
B18	813 4039	Motor, 230V	1	C17	4,2x12 DIN 7981	Screw	8
-	813 4040	Motor, 110V	1	C18	M10x40 DIN 931	Screw	1
B19	443 4056	Drive belt	1	C19	653 4067	Washer	10
B20	433 4069 20	Anti-slip mat,pair	1	C20	523 4064	Fixing tube	2
B21	433 4070 20	Side landing	2	C21	M10x32 ISO 7380	Hexagon screw	2
B22	433 4065	Running deck	1	C22	523 4065	Fixing tube	2
B23	443 4055 20	Running belt	1	C24	M10x12 ISO 4032	Hexagon screw	2
B24	693 4008	Belt guide	2	C25	M10x25 ISO 7380	Hexagon screw	2
B25	403 4185	Overcurrent protector	1	C26	523 4064	Fixing tube	2
B26	403 4186	Power socket	1	C27	M10 DIN 125	Washer	2
B27	403 4134 EU	Power cable	1	C28	M10x70 DIN 912	Screw	2
-	403 4134 USA	Power cable	1	C29	M10 DIN 6798A	Washer	2
-	403 4134 GB	Power cable	1	C30	M8 DIN 125	Washer (*2 pcs)	10
-	403 4134 ISR	Power cable	1	C31	M8x28 ISO 7380	Hexagon screw	2
-	403 4134 SUI	Power cable	1	C32	M6x12 DIN 7985	Screw (*2 pcs)	4
-	403 4168 AUS	Power cable	1	C33	643 4010	Spring	1
B28	813 4038	Lift motor	1	C34	M8x15 ISO 7380	Hexagon screw	4
B29	503 4094	Wire holder	3	C35	M8x40 ISO 7380	Hexagon screw	4
B30	403 4169	Speed sensor	1	C36	653 4068	Plastic washer	2
B31	503 4091	Motor cover bracket	4	C37	M8x25 DIN 912	Hexagon socket cap screw	4
B32	533 4133	Rubber bumper	8	-	423 4152 20	Label set	1
B33	533 4141 20	Rear end cap, LH	1	-	553 4029 20	Assembly kit (incl. *)	1
B34	533 4142 20	Rear end cap, RH	1	*	556 032 00	Allen key, 6mm	1
B35	533 4128	Wheel	4	*	553 101 88	Screw wrench	1
B36	533 4129	Wheel	2	-	583 4035 20	Owner's manual	1
B37	173 4128 20	Incline bracket cover, LH	1				
B38	173 4127 20	Incline bracket cover, RH	1				
B39	683 4017	Bumper	2				

Ambition (441519)

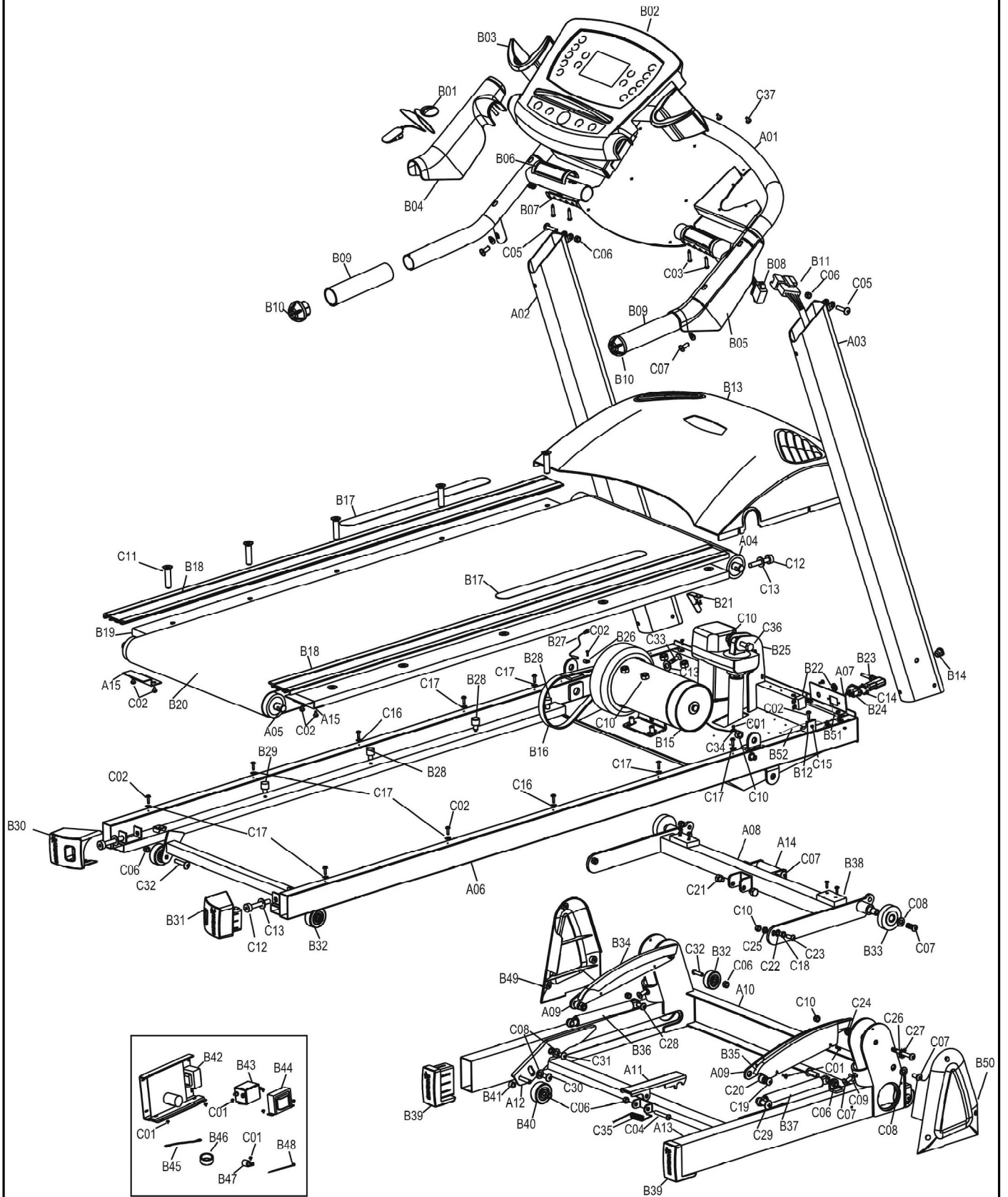

Ambition

Item	Part No	Description	Unit	Item	Part No	Description	Unit
A01	103 4092 20	Console base	1	B39	533 4145 20	Front support end cap	2
A02	203 4078 20	Handlebar, LH	1	B40	533 4127	Wheel	2
A03	203 4079 20	Handlebar, RH	1	B41	653 4064	Plastic washer	2
A04	523 4062	Front roller	1	B42	403 4183	Power board, 230V	1
A05	523 4063	Rear roller	1	-	403 4184	Power board, 110V	1
A06	103 4077 20	Frame	1	B43	403 4174	Filter, EUR	1
A07	503 4089 20	Switch bracket	1	B44	403 4175	Transformer, EUR	1
A08	103 4090 20	Incline structure frame	1	B45	403 4176	Wire set (incl. B45, B51, B52)	1
A09	503 4090 20	Incline bracket	2	B46	403 4181	Ferrite	2
A10	103 4078 20	Front support frame	1	B47	503 4095	Wire holder	2
A11	373 4014 20	Locking lever	1	B48	502 802 74	Plastic fixer	2
A12	533 4134 20	Wheel bracket LH	1	B49	173 4157 20	Front support cover, LH	1
A13	533 4135 20	Wheel bracket RH	1	B50	173 4158 20	Front support cover, RH	1
A14	343 4022 20	Lockin lever shaft	1	C01	M4x6 DIN 7500 C	Screw	18
A15	433 4047	Z-plate	2	C02	4,2x12 DIN 7981	Screw (*4 pcs)	27
B01	403 4182	Safety key	1	C03	3,5x16 DIN 7981	Screw	4
B02	233 4053 20	User interface	1	C04	M8x55 ISO 7380	Hexagon screw	1
B03	173 4156 20	Bottle holder,	2	C05	M8x35 ISO 7380	Hexagon screw	2
B04	173 4154 20	Handlebar cover, LH	1	C06	M8 DIN 985	Locking nut	11
B05	173 4155 20	Handlebar cover, RH	1	C07	M8x20 ISO 7380	Hexagon screw (*6 pcs)	8
B06	403 4190 20	Hand pulse, upper	2	C09	653 4066	Washer (*4 pcs)	4
B07	403 4191 20	Hand pulse, lower	2	C08	M8 DIN 125	Washer (*2 pcs)	8
B08	403 4170	Wire set (incl. B11)	1	C10	M10 DIN 985	Nylock nut	11
B09	213 4029 20	Handle grip	2	C11	M6x25 DIN 7991	Countersunk head screw	10
B10	533 4147 20	End cap	2	C12	M8x55 DIN 912	Hexagon socket cap screw	3
B12	503 4091	Motor cover bracket	4	C13	M8 DIN 125	Washer	4
B13	173 4152 20	Motor cover	1	C14	2,9x10 DIN 7982	Screw	2
B14	533 4140	Through-leading rubber	1	C15	4,2x12 DIN 7981	Screw	8
B15	813 4039	Motor, 230V	1	C17	653 4067	Washer	8
-	813 4040	Motor, 110V	1	C18	523 4064	Fixing tube	2
B16	443 4056	Drive belt	1	C19	M10x32 ISO 7380	Hexagon screw	2
B17	433 4069 20	Anti-slip mat,pair	1	C20	523 4065	Fixing tube	2
B18	433 4070 20	Side landing	2	C21	M10x12 ISO 4032	Hexagon screw	2
B19	433 4065	Running deck	1	C22	653 4068	Washer	2
B20	443 4055 20	Running belt	1	C23	M10x25 ISO 7380	Hexagon screw	2
B21	693 4008	Belt guide	2	C24	523 4068	Fixing tube	2
B22	403 4185	Overcurrent protector	1	C25	M10 DIN 125	Washer	2
B23	403 4134 EU	Power cable	1	C26	M10x70 DIN 912	Screw	2
-	403 4134 USA	Power cable	1	C27	M10 DIN 6798A	Washer	2
-	403 4134 GB	Power cable	1	C28	M8x28 ISO 7380	Hexagon screw	2
-	403 4134 ISR	Power cable	1	C29	M6x12 DIN 7985	Screw	2
-	403 4134 SUI	Power cable	1	C30	M8x20 ISO 7380	Hexagon screw	2
-	403 4168 AUS	Power cable	1	C31	M8x15 ISO 7380	Hexagon screw	2
B24	403 4186	Power socket	1	C32	M8x40 ISO 7380	Hexagon screw	4
B25	813 4038	Lift motor	1	C33	M8x50 DIN 933	Hex screw	1
B26	503 4094	Wire holder	3	C34	M5 DIN 6798I	Star washer	5
B27	403 4169	Speed sensor	1	C35	643 4010	Spring	1
B28	533 4133	Rubber bumper	6	C36	M10x40 DIN 931	Screw	1
B29	533 4150	Rubber bumper	2	C37	M5x12 DIN 7985	Screw	14
B30	533 4141 20	Rear end cap, LH	1	-	423 4151 20	Label set	1
B31	533 4142 20	Rear end cap, RH	1	-	553 4029 20	Assembly kit (incl. *)	1
B32	533 4128	Wheel	4	*	556 032 00	Allen key, 6mm	1
B33	533 4129	Wheel	2	*	553 101 88	Screw wrench	1
B34	173 4128 20	Incline bracket cover, LH	1	-	583 4039 20	Owner's manual	1
B35	173 4127 20	Incline bracket cover, RH	1				
B36	163 4011	Gas spring	2				
B38	683 4017	Bumper	2				