

Discover SE3 / SE3HD

Treadmill, Cross-Trainer, Upright and Recumbent Lifecycle® Exercise Bikes, FlexStrider™ Variable-Stride Trainer, PowerMill™ Climber, Arc Trainer™

Service Manual



LifeFitness

Corporate Headquarters

Columbia Centre III, 9525 West Bryn Mawr Avenue, Rosemont, Illinois 60018 • U.S.A.
847.288.3300 • FAX: 847.288.3703
Service phone number: 800.351.3737 (toll-free within U.S.A., Canada)
Global Website: www.lifefitness.com

International Offices

AMERICAS

North America

Life Fitness, Inc.

Columbia Centre III
9525 West Bryn Mawr Avenue
Rosemont, IL 60018 U.S.A.
Telephone: (847) 288 3300
Service Email:
customersupport@lifefitness.com
Sales/Marketing Email:
commercialsales@lifefitness.com

Brazil

Life Fitness Brasil

Av. Rebouças, 2315
Pinheiros
São Paulo, SP 05401-300
BRAZIL
SAC: 0800 773 8282 option 2
Telephone: +55 (11) 3095 5200 option 2
Service Email: suportebr@lifefitness.com
Sales/Marketing Email:
vendasbr@lifefitness.com

Latin America and Caribbean*

Life Fitness, Inc.

Columbia Centre III
9525 West Bryn Mawr Avenue
Rosemont, IL 60018 U.S.A.
Telephone: (847) 288 3300
Service Email:
customersupport@lifefitness.com
Sales/Marketing Email:
commercialsales@lifefitness.com

EUROPE, MIDDLE EAST, and AFRICA (EMEA)

Netherlands and Luxemburg

Life Fitness Atlantic BV

Bijdorpplein 25-31
2992 LB Barendrecht
THE NETHERLANDS
Telephone: (+31) 180 646 666
Service Email:
service.benelux@lifefitness.com
Sales/Marketing Email:
marketing.benelux@lifefitness.com

United Kingdom

Life Fitness UK LTD

Queen Adelaide
Ely, Cambs, CB7 4UB
Telephone: General Office (+44)
1353.666017
Customer Support (+44) 1353.665507
Service Email: uk.support@lifefitness.com
Sales/Marketing Email: life@lifefitness.com

Germany, Austria, and Switzerland

Life Fitness Europe GMBH

Neuhofweg 9
85716 Unterschleißheim
GERMANY
Telephone:
+49 (0) 89 / 31775166 Germany
+43 (0) 1 / 6157198 Austria
+41 (0) 848 / 000901 Switzerland
Service Email:
kundendienst@lifefitness.com
Sales/Marketing Email:
vertrieb@lifefitness.com

Spain

Life Fitness IBERIA

C/Frederic Mompou 5,1ª^a
08960 Sant Just Desvern Barcelona
SPAIN
Telephone: (+34) 93.672.4660
Service Email:
servicio.tecnico@lifefitness.com
Sales/Marketing Email:
info.iberia@lifefitness.com

Belgium

Life Fitness Benelux NV

Parc Industriel de Petit-Rechain
4800 Verviers
BELGIUM
Telephone: (+32) 87 300 942
Service Email:
service.benelux@lifefitness.com
Sales/Marketing Email:
marketing.benelux@lifefitness.com

All Other EMEA Countries and Distributor Business EMEA*

Bijdorpplein 25-31
2992 LB Barendrecht
THE NETHERLANDS
Telephone: (+31) 180 646 644
Service Email:
EMEAServiceSupport@lifefitness.com

ASIA PACIFIC (AP)

Japan

Life Fitness Japan, Ltd

4-17-33 Minami Aoyama 1F/B1F
Minato-ku - Tokyo 107-0062
Japan
Telephone: (+81) 0120.114.482
Fax: (+81) 03-5770-5059
Service Email: service.lfj@lifefitness.com
Sales/Marketing Email:
sales@lifefitnessjapan.com

Hong Kong

Life Fitness Asia Pacific LTD

32/F, Global Trade Square
21 Wong Chuk Hang Road
Hong Kong
Telephone: (+852) 2575.6262
Service Email: Service.HK@lifefitness.com
Sales/Marketing Email:
hongkong.sales@lifefitness.com

All Other Asia Pacific countries and distributor business Asia Pacific*

32/F, Global Trade Square
21 Wong Chuk Hang Road
Hong Kong
Telephone: (+852) 2575.6262
Fax: (+852) 2575.6894
Service Email: Service.AP@lifefitness.com
Sales/Marketing Email:
Marketing.HK.Asia@lifefitness.com

*Also check www.lifefitness.com for local representation or distributor/dealer

Table of Contents

Safety

Safety Instructions.....	4
Before Use.....	7
Functional Information.....	9
Immobilization Method.....	10
Icons Used In This Manual.....	12

Introduction

Using this Manual.....	13
Customer Support Contact Information.....	13
Online References.....	13
Related Products.....	14

Maintenance

Preventive Maintenance Tips.....	15
Approved and Compatible Cleaners.....	15

Theory of Operation

Carrier Board (PCB-001).....	16
COM Board - IMX6 (PCB-002).....	17
MIB (PCB-003).....	18
Bluetooth Module (PCB-005).....	19
USB / Headphone Board (PCB-007).....	20
Apple Authentication Board (PCB-004).....	21
Touch Controller Board (PCB-006).....	22
Tuner Boards.....	23
STB-SYNC Receiver Board.....	25
Wireless Connectivity Module.....	26
RFID Module.....	27

How To's

Knowledge Base.....	28
How to Clone TV tuner settings through USB.....	28
How to Calibrate the Touch Screen.....	30
How to extract LOG / Information from console.....	31

Troubleshooting

Knowledge Base.....	32
Troubleshooting.....	32
Troubleshooting - Heart Rate Reading.....	33
Troubleshooting - Life Fitness On Demand™.....	34
No Power at Console.....	34
Wireless Bluetooth Headphones.....	34
Internet Issues at the Console.....	35

Software

Choose Your Workout.....	38
Update Console Software.....	42

How to perform a System Recovery for the Console.....	46
---	----

Diagnostics

Accessing System Options.....	48
Manager - Default Settings.....	50

Error code list

Error 20.....	54
Error 21.....	55
Error 25.....	56
Error 26.....	57
Error 27.....	58
Error 31.....	59
Error 33.....	60
Error 34.....	61
Error 38.....	62
Error 39.....	63
Error 47.....	64
Error 49.....	65
Error 60.....	66
Error 61.....	67
Error 62.....	68
Error 63.....	69
Error 64.....	70
Error 66.....	71
Error 70.....	73
Error 71.....	74
Error 72.....	76
Error 73.....	77
Error 74.....	78
Error 75.....	79
Error 76.....	80
Error 77.....	81
Error 78.....	82
Error 79.....	83
Error 80.....	84
Error 81.....	85
Error 82.....	86
Error 83.....	87
Error 84.....	88
Error 89.....	89
Error 90.....	90
Error 91.....	91
Error 93.....	92
Error 94.....	93
Error 101.....	94
Error 110.....	95
Error 120.....	96

Error 121.....	97	Exclusive Warranty.....	126
Error 122.....	98	Changes in Warranty Not Authorized.....	127
Error 123.....	99	Effects of State Laws.....	127
Error 124.....	100	Warranty Information.....	127
Error 125.....	101		
Error 126.....	102		
Error 127.....	103		
Error 128.....	104		
Error 129.....	105		
Error 131.....	106		
Error 132.....	107		
Error 135.....	108		
Error 136.....	109		
Error 137.....	110		
Error 138.....	111		
Error 141.....	112		
Error 142.....	113		
Error 143.....	114		
Error 148.....	115		
Error 149.....	116		
Error 151.....	117		
Error 152.....	118		
Error 153.....	119		
Error 155.....	120		
Error 157.....	121		
Error 601.....	122		
Error 602.....	123		

Schematics

Online References.....	124
------------------------	-----

Glossary

Connectors.....	125
LCD.....	125
LED.....	125
Lifepulse™.....	125
MDB.....	125
MIB.....	125
NFC.....	125
PCB.....	125
SIB.....	125

Warranty

What is Covered.....	126
Who is Covered.....	126
How Long It is Covered.....	126
Who Pays Transportation and Insurance For Service.....	126
What We Will Do To Correct Covered Defects.....	126
What is Not Covered.....	126
What You Must Do.....	126
How to Get Parts and Service.....	126

1. Safety

Safety Instructions

Read all instructions before use.

ALL PRODUCTS



CAUTION: Any changes or modifications to this equipment could void the product warranty.



WARNING: To reduce the risk of burns, fire, electric shock, or injury, it is imperative to connect each product to a properly grounded electrical outlet.



WARNING: Heart rate monitoring systems may be inaccurate. Over exercising may result in serious injury or death. If you feel faint, stop exercising immediately.



DANGER: To reduce the risk of electrical shock or injury from moving parts, always unplug product before cleaning or attempting any maintenance activity.

- Never operate the product if it has a damaged power cord or electrical plug, or if it has been dropped, damaged, or even partially immersed in water. Contact Customer Support Services.
- Position the product so that the power cord plug to the wall is accessible to the user. Make sure that the power cord is not knotted or twisted and that it is not trapped under any equipment or other objects.
- If the electrical supply cord is damaged, it must be replaced by the manufacturer, an authorized service agent, or a similarly qualified person to avoid a hazard.
- Always follow the console instructions for proper operation.
- This appliance is not intended for use by persons (including children) with reduced physical, sensory, or mental capabilities, or lack of experience or knowledge unless they have supervision or been given instruction concerning the use of the appliance by a person responsible for their safety.
- Do not use this product outdoors, near swimming pools or in areas of high humidity.
- Never operate the product with the air openings blocked. Keep air openings free of lint, hair, or any other obstructing material.
- Never insert objects into any opening in these products. If an object should drop inside, turn off the power, unplug the power cord from the outlet, and carefully retrieve it. If the item cannot be reached, contact Customer Support Services.
- Never place liquids of any type directly on the unit, except in an accessory tray or holder. Containers with lids are recommended.
- Do not use these products in bare feet. Always wear shoes. Wear shoes with rubber or high-traction soles. Do not use shoes with heels, leather soles, cleats or spikes. Make sure no stones are embedded in the soles.
- Keep all loose clothing, shoelaces, and towels away from moving parts.
- Do not reach into, or underneath, the unit or tip it on its side during operation.
- This equipment is not intended for use by children. Keep children under the age of 14 away from the machine.
- Do not allow other people to interfere in any way with the user or equipment during a workout.
- Allow LCD consoles to “normalize” with respect to temperature for one hour before plugging the unit in and using.
- Use these products for their intended use as described in this manual. Do not use attachments that have not been recommended by the manufacturer.
- Free standing equipment shall be installed on a stable and leveled surface.
- Read all warnings on each product prior to starting a workout.
- If warnings are missing or damaged, please contact Customer Support Services immediately for replacement warning labels. Warning labels are shipped with every product and should be installed before product is used. Life Fitness is not responsible for missing or damaged warning labels.

TREADMILL



CAUTION: Risk of injury to persons - to avoid injury, use extreme caution when stepping onto or off of a moving belt. Read assembly instruction manual before using.



WARNING: Keep the area 6.5 ft. (2 m) by 3 ft. (0.9 m) behind the treadmill clear of any obstructions, including walls, furniture, and other equipment. Contact Customer Support Services for an optional longer power cord if necessary.



WARNING: Be sure the emergency stop lanyard is clipped to the user and in proper position on the treadmill before beginning any workout.





WARNING: The belt centering adjustment must be performed if the belt is not between the marks indicating the maximum allowed lateral positions. Refer to Treadmill Assembly Instructions.

 **WARNING:** This product can expose you to chemicals including Acrylonitrile, which is known to the State of California to cause cancer and birth defects or other reproductive harm. For more information go to <http://www.P65Warnings.ca.gov>

- The product should never be left unattended when plugged in. Disconnect from the electrical outlet when not in use, and before putting on or taking off parts. To disconnect, turn power OFF at the ON/OFF switch, then remove plug from electrical outlet.
- Keep the power cord away from heated surfaces. Do not pull the equipment by the power cord or use the cord as a handle. Do not run the power cord on the floor under or along the side of the treadmill.
- Handrails may be held to enhance stability as needed, but are not for continuous use.
- Never mount or dismount the treadmill while the running belt is moving. Use the handrails whenever additional stability is required. In case of an emergency, such as tripping, grasp the handrails, and place the feet on the side platforms.
- Never walk or jog backwards on the treadmill.
- Do not use this product in areas where aerosol spray products are being used or where oxygen is being administered. Such substances create the danger of combustion and explosion.
- In conformity with the European Union Machinery Directive 2006/42/EC, this equipment unloaded runs at sound pressure levels below 70 dB (A) at the average operating speed of 12 km/hr. Noise emission under load is higher than without load.

LIFECYCLE® EXERCISE BIKES

 **WARNING:** Allow a distance of 16 in. (41 cm) between the widest part of the bike and other objects on either side. Provide at least 3 ft. (0.9 m) between the front or rear of the bike to any other objects and 2 ft. (0.6 m) in the direction the equipment is accessed from.

 **WARNING:** This product can expose you to chemicals including Acrylonitrile, which is known to the State of California to cause cancer and birth defects or other reproductive harm. For more information go to <http://www.P65Warnings.ca.gov>

- Do not stand or sit on plastic shrouds.
- Use caution when mounting or dismounting the bike. Use the stationary handlebar whenever additional stability is required.

ARC TRAINER

 **WARNING:** Ensure that there is at least 23.6" (0.6 m) of clearance behind the product and at least 12" (30 cm) on the sides.

 **WARNING:** The product is not equipped with a free-wheeling feature. Therefore, it cannot be stopped immediately.

 **WARNING:** Moving parts and fall hazard.

- To avoid serious injury wait until foot plates come to a complete stop before getting off unit.
- The moving parts cannot be stopped immediately, the unit is not equipped with a free wheel.

 **WARNING:** This product can expose you to chemicals including Di-2-ethylhexyl-phthalate, which is known to the State of California to cause cancer and birth defects or other reproductive harm. For more information go to <http://www.P65Warnings.ca.gov>

- The individual human power required to perform an exercise may be different than the mechanical power displayed on the product.
- Use caution when mounting or dismounting the product. Before mounting, use the moving arms to bring the foot plate nearest to you to the lowest position. Use the stationary handlebars whenever additional stability is required. While exercising, hold onto the moving arms.
- Never face backward while using the product.

CROSS-TRAINER and FLEXSTRIDER

 **WARNING:** Ensure that there is at least 1 ft. (0.3 m) of clearance in front of the Cross-Trainer and at least 2 ft. (0.6m) on the side.

 **WARNING:** Ensure that there is at least 2 ft. (0.6m) of clearance behind and on each side of the FlexStrider.

 **WARNING:** The Cross-Trainer and FlexStrider are not equipped with a free-wheeling feature. Therefore, the products cannot be stopped immediately.

FlexStrider

 **WARNING:** This product can expose you to chemicals including Di-2-ethylhexyl-phthalate, which is known to the State of California to cause cancer and birth defects or other reproductive harm. For more information go to <http://www.P65Warnings.ca.gov>

Cross-Trainer

 **WARNING:** This product can expose you to chemicals including Acrylonitrile, which is known to the State of California to cause cancer and birth defects or other reproductive harm. For more information go to <http://www.P65Warnings.ca.gov>

- Do not stand or sit on the rear plastic covers of the Cross-Trainer.
- Do not stand on center tube of the Cross-Trainer.
- The individual human power required to perform an exercise may be different than the mechanical power displayed on the Cross-Trainer and FlexStrider.
- Use caution when mounting or dismounting the Cross-Trainer and FlexStrider. Before mounting, use the moving arms to bring the pedal nearest to you to the lowest position. Use the stationary handlebars whenever additional stability is required. While exercising, hold onto the moving arms.
- Never face backward while using the Cross-Trainer or FlexStrider.

POWERMILL™ CLIMBER

 **WARNING:** Keep a distance of at least 3 ft. (1 m) behind and 1 ft. (0.3 m) on each side of the unit clear of any obstructions, including walls, furniture, and other equipment.

- Handrails may be held to enhance stability as needed, but are not for continuous use.
- The product should never be left unattended when plugged in. Disconnect from the electrical outlet when not in use, and before putting on or taking off parts. To disconnect, turn power OFF at the ON/OFF switch, then remove plug from electrical outlet.
- Never walk or jog backwards on the PowerMill Climber.
- Unlike bikes, cross-trainers, or the traditional paddle stairclimbers, this is a motorized product. This motorized product causes stair steps to descend at variable rates and therefore operates on different planes simultaneously. While operating the product during a typical workout, the user is forced to fully concentrate on coordinating his or her efforts on the moving stairs. Therefore, the user cannot see if anyone or anything approaches from the rear. For these reasons this unit is **designed for use only in a controlled setting. The PowerMill Climber is not designed for use in the home and should not be used in an environment where children or animals might have access.**

SAVE THESE INSTRUCTIONS FOR FUTURE REFERENCE.

Before Use

Before using this product, it is essential to read this ENTIRE operation manual and ALL assembly instructions. It describes equipment setup and instructs members on how to use it correctly and safely.

Any service, other than cleaning or user maintenance, must be performed by an authorized service representative.



CAUTION: Any changes or modifications to this equipment could void the product warranty.

FCC Warning - Possible Radio / Television Interference

EN ISO 20975 Class SA (Bikes and Arc Trainer only): Professional and / or commercial use.

EN ISO 20975 Class SB (Treadmill only): Professional and / or commercial use.

EN ISO 20957 Class S: Professional and / or commercial use.

NOTE: This equipment has been tested and found to comply with the limits for a Class A digital device, pursuant to part 15 of the FCC rules. These limits are designed to provide reasonable protection against harmful interference when the equipment is operated in a commercial environment. This equipment generates, uses and can radiate radio frequency energy, and if not installed and used in accordance with the instruction manual, may cause harmful interference to radio communications. Operation of this equipment in a residential area is likely to cause harmful interference in which case the user will be required to correct the interference at his own expense.

EN ISO 20957 Class H: Home use.

NOTE: This equipment has been tested and found to comply with the limits for a Class B digital device, pursuant to part 15 of the FCC rules. These limits are designed to provide reasonable protection against harmful interference in a residential installation. This equipment generates, uses and can radiate radio frequency energy, and if not installed and used in accordance with the user manual, may cause harmful interference to radio communications. However, there is no guarantee that the interference will not occur in a particular installation. If this equipment does cause harmful interference to radio or television reception, which can be determined by turning the equipment off and on, the user is encouraged to try to correct the interference by one or more of the following measures:

- Reorient or relocate the receiving antenna.
- Increase the separation between the equipment and the receiver.
- Connect the equipment into an outlet on a circuit different from that to which the receiver is connected.
- Consult the dealer or an experienced radio/TV technician for help.

Cross-Trainers only:

Cross-Trainers:

For EN ISO 20957-9: 2016 Class SA accuracy testing, power at the crankshaft was measured by connecting the training equipment to a dynamometer. The crank was rotated and torque measured per EN ISO 20957-9: 2016 Class SA operating test conditions. Accuracy of the resulting watts displayed on the console and actual watts measured by dynamometer were found to be within the tolerance of EN ISO 20957-9: 2016 Class SA (+/- 5 Watts up to 50 Watts and +/- 10% over 50 Watts).

FlexStrider Variable Stride Trainer only:

For EN ISO 20957-9 Class A accuracy testing, input mechanical power was measured by connecting the resistance device (generator) with the console to a dynamometer. Torque test data was recorded across the available speed and resistance level settings. The mechanical resistance was then determined by a deceleration test without a user riding it, measuring precisely both motions exhibited by the product: 1) The rotational deceleration measured from the starting speed and time, at minimum stride, until the rotating mechanism comes to a stop, and 2) The angular deceleration measured from a starting angle and time until the pedal leg lever assembly comes to a stop. The torque required to stop the unit was then calculated from the system inertia, input speed, angle, and time to stop, and then added to the dynamometer data to obtain the total system torque. From measured torque and speed, the input mechanical power and variance from displayed power were calculated. At level 10 and a constant 40 RPM, displayed wattage was 128 watts, with a 2.1% variance from input power on the test equipment. At level 15 and a constant 60 RPM, displayed wattage was 167 watts, with a 4.6% variance from input power on the test equipment.

Arc Trainer only:

Arc Trainers:

For EN ISO 20957-9: 2016 Class SA accuracy testing, power at the crankshaft was measured by connecting the training equipment to a dynamometer. The crank was rotated and torque measured per EN ISO 20957-9: 2016 Class SA

operating test conditions. Accuracy of the resulting watts displayed on the console and actual watts measured by dynamometer were found to be within the tolerance of EN ISO 20957-9: 2016 Class SA (\pm 5 Watts up to 50 Watts and \pm 10% over 50 Watts).

Functional Information

This Owner's Manual describes the functions of the Discover SE3HD console with the following bases:

- *Elevation Series Treadmill, Cross-Trainer, Upright and Recumbent Lifecycle® Exercise Bikes, FlexStrider™ Variable Stride Trainer*
- *Platinum Club Series Treadmill, Cross-Trainer, Upright and Recumbent Lifecycle® Exercise Bikes*
- *Integrity Series Treadmill, Cross-Trainer, Upright and Recumbent Lifecycle® Exercise Bikes*
- *Club Series + Treadmill, Cross-Trainer, Upright and Recumbent Lifecycle® Exercise Bikes*
- *PowerMill™ Climber*
- *Arc Trainer*

Statements of Purpose:

- The *Life Fitness* Treadmill is an exercise machine that enables users to walk or run, in place, indoors on a moving surface.
- The *Life Fitness* Cross-Trainer is an exercise machine that combines low-impact elliptical pedaling with push / pull arm motion to provide an efficient, effective total body workout indoors.
- The *Life Fitness* Lifecycle Exercise Bike is a machine that simulates the movements of riding a bicycle indoors at various speeds and levels of resistance.
- The *Life Fitness* FlexStrider Variable-Stride Trainer is a commercial exercise machine that allows exercisers to instantly choose the length of an elliptical stride for a total-body, low-impact workout.
- The *Life Fitness* PowerMill Climber is a commercial exercise machine that enables users to scale a revolving staircase at a wide variety of speeds.
- The *Life Fitness* Arc Trainer is a non-impact, weight bearing cross trainer, used by applying force to the foot pedals.



WARNING: Keep batteries out of reach of children.

Some chest straps may contain a removable battery.

- Swallowing may lead to serious injury in as little as 2 hours or death, due to chemical burns and potential perforation of the esophagus.
- If you suspect your child has swallowed a battery, immediately call your local poison control for fast, expert advice.
- Examine devices and make sure the battery compartment is correctly secured, e.g. that the screw or other mechanical fastener is tightened. Do not use if compartment is not secure.
- Dispose of used button batteries immediately and safely. Flat batteries can still be dangerous.
- Tell others about the risk associated with button batteries and how to keep their children safe.



WARNING: Health-related injuries may result from incorrect or excessive use of exercise equipment. Life Fitness STRONGLY recommends seeing a physician for a complete medical exam before undertaking an exercise program, particularly if the user has a family history of high blood pressure or heart disease, is over the age of 45, smokes, has high cholesterol, is obese, or has not exercised regularly in the past year. If, at any time while exercising, the user experiences faintness, dizziness, pain, or shortness of breath, he or she must stop immediately.

Immobilization Method

A software update created a new method to immobilize a treadmill. Use one of the following procedures for your console:

- [Immobilization Method - Prior to software version 4.8.46](#)
- [Immobilization Method - After software version 4.09](#)

Immobilization Method - Prior to software version 4.8.46

The purpose of immobilizing the treadmill is to prevent unauthorized use. The system causes immobilization of the treadmill when activated.

1. Go to the Workouts Selection Screen.
2. The touch sequence is **UPPER-LEFT**, **UPPER-RIGHT**, **UPPER-LEFT**, and **UPPER-RIGHT**.

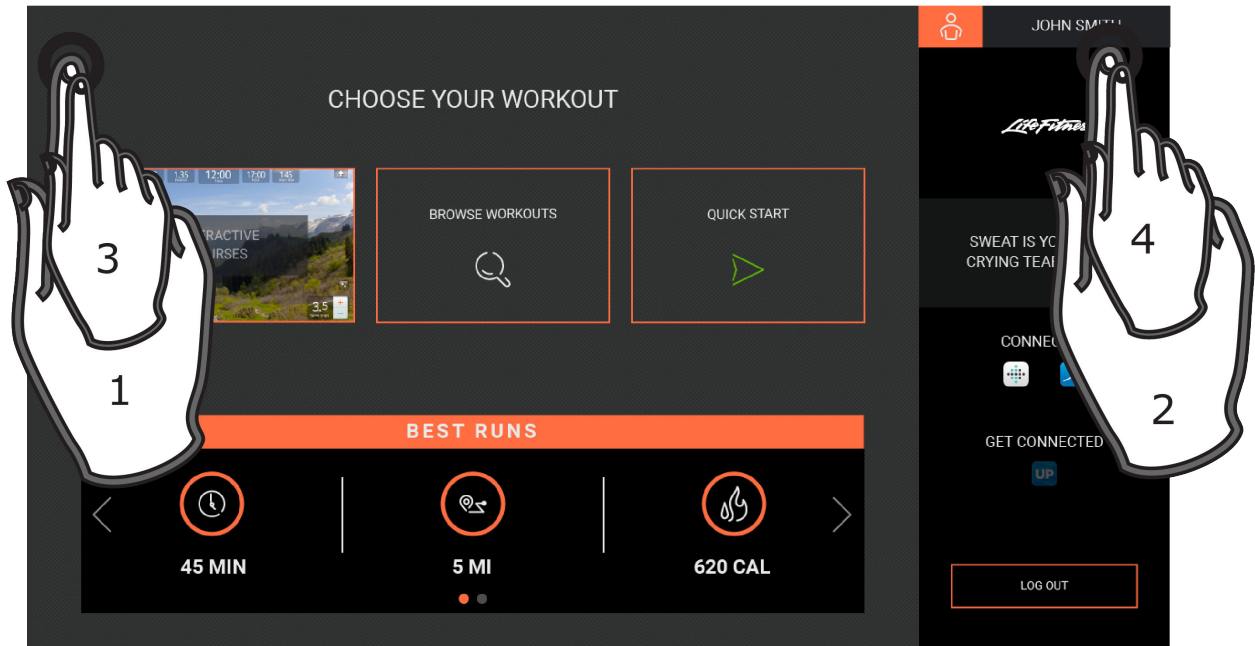

3. Tap the **Immobilize Unit** icon. **Enabled** will be displayed.



Item	Description	Qty.
1	Immobilize Unit icon	1
2	Enabled icon	1
3	Exit icon	1

4. Tap the exit icon **X** to exit **System Options**.

To turn immobilization off, enter **System Options** and tap the **Immobilize Unit** icon to disable.

Immobilization Method - After software version 4.09

The purpose of immobilizing the treadmill is to prevent unauthorized use. The system causes immobilization of the treadmill when activated.

1. Tap the **LANGUAGE** icon to access the **SELECT LANGUAGE** screen.
2. Tap the lower part of the screen in the following sequence: **Lower-Left**, **Lower-Right**, **Lower-Left**, and **Lower-Right**.

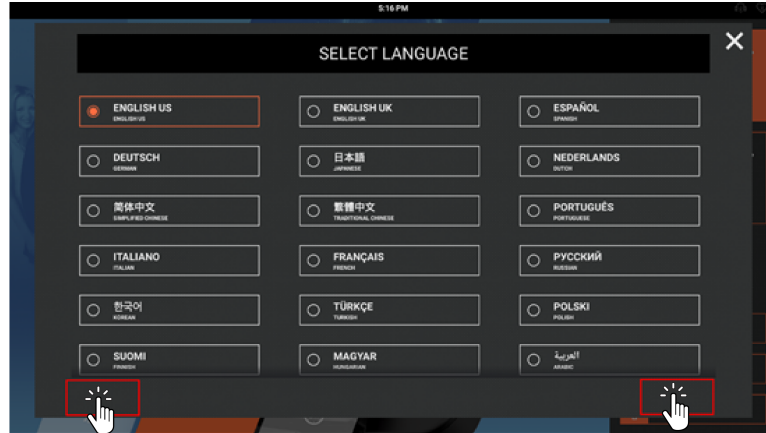

3. Tap the **Immobilize Unit** icon. **Enabled** will be displayed.

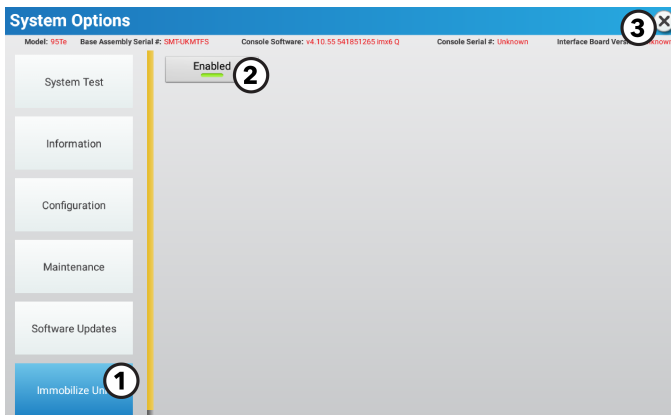

Item	Description
1	Immobilize Unit icon
2	Enabled icon
3	Exit icon

4. Tap the exit icon **X** to exit **System Options**.
5. Unit will shutdown.
6. **UNIT IMMOBILIZED BY MANAGER** message appears on screen.
7. Tap the upper part of the **ATTRACT SCREEN** in the following sequence: **Upper-Left**, **Upper-Right**, **Upper-Left**, and **Upper-Right** to enter **System Options**.
8. Tap the **Immobilize Unit** icon to disable.

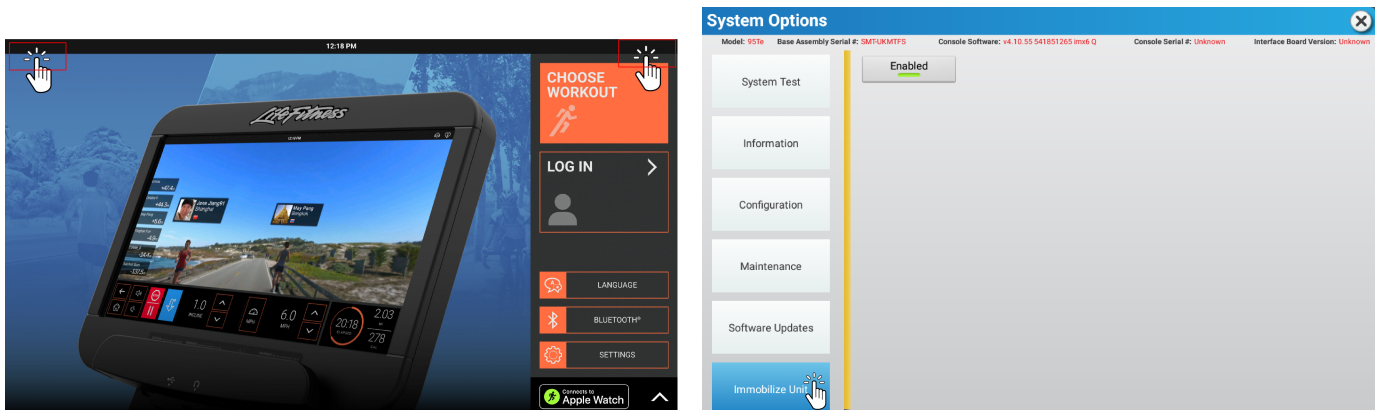

Icons Used In This Manual

This manual covers information for multiple cardio products. To help differentiate we use the following icons.

	Treadmill-Only Feature
	Cross-Trainer-Only Feature
	Bike-Only Feature
	FlexStrider-Only Feature
	PowerMill-Only Feature
	Arc Trainer-Only Feature

2. Introduction

Using this Manual

This service manual provides safe and efficient test and service procedures.

Descriptions using the words "left" and "right" refer to the orientation of a user using the product, facing the console. "Front" is the area of the product with the console. The "Rear" of the product is behind the user.

Customer Support Contact Information

Refer to [Corporate Headquarters](#) for contact info.

To speed Customer Support Service's response, please provide the following information to the customer support technician:

- Serial number
- Model number
- Part name
- Part number
- Symptom of problem

Serial Number Location

The serial number is located under the bottom right corner of the console.

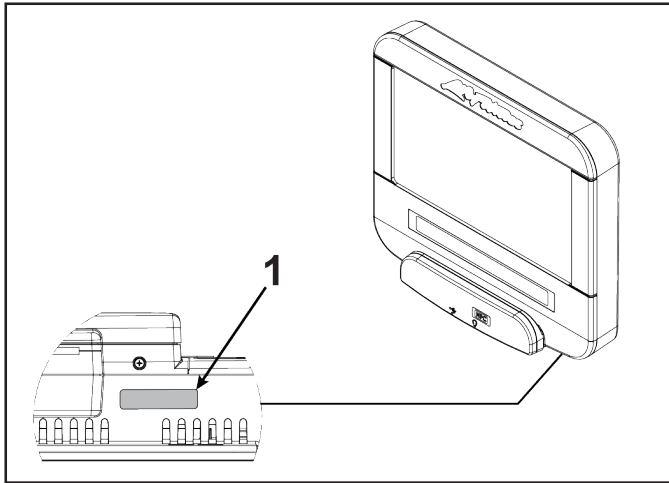

Item	Description
1	Serial number decal

Online References

Detailed Schematics are available online in Parts Manuals:

- <https://www.lftechsupport.com> access technical documentation and part manuals for Life Fitness, Hammer Strength, and ICG.
- <http://www.lifefitness.com/parts> service parts ordering for Life Fitness, Cybex, SCIFIT, Hammer Strength, and ICG products along with warranty parts ordering and technician requests.
- <https://lfworld.lifefitness.com> easy to find Knowledge Base articles with answers to frequently asked questions and product support documentation for Life Fitness, Cybex, SCIFIT, Hammer Strength, and ICG.

Related Products

The *Discover SE3HD* console is used on the following products:

- Arc Trainer
- Integrity Series Treadmill
- Integrity Series Elliptical Cross-Trainer
- Integrity Series Recumbent Lifecycle® Exercise Bike
- Integrity Series Upright Lifecycle® Exercise Bike
- PowerMill Climber

3. Maintenance

Preventive Maintenance Tips

NOTE: Safety of the equipment can be maintained only if the equipment is examined regularly for damage or wear. Keep the equipment out of use until defective parts are repaired or replaced. Pay special attention to parts that are subject to wear, as outlined below.

The following preventive maintenance tips will keep the product operating at peak performance:

- Locate the product in a cool, dry place.
- Clean the display console and all exterior surfaces with an approved or compatible cleaner (see [Approved and Compatible Cleaners](#)) and a microfiber cloth.
- Long fingernails may damage or scratch the surface of the console; use the pad of the finger to press the selection buttons on the console.

Approved and Compatible Cleaners

Two preferred cleaners have been approved by reliability experts: PureGreen 24 and Gym Wipes. Both cleaners will safely and effectively remove dirt, grime and sweat from equipment. PureGreen 24 and the Antibacterial Force formula of Gym Wipes are both disinfectants that are effective against MRSA and H1N1.

PureGreen 24 is available in a spray which is convenient for gym staff to use. Apply the spray to a microfiber cloth and wipe down the equipment. Use PureGreen 24 on the equipment for at least 2 minutes for general disinfection purposes and at least 10 minutes for fungus and viral control.

Gym Wipes are large, durable pre-moistened wipes to use on the equipment before and after workouts. Use Gym Wipes on the equipment for at least 2 minutes for general disinfection purposes.

Contact Customer Support Services to order these cleaners (1-800-351-3737 or email: customersupport@lifefitness.com).

Mild soap and water or a mild non-abrasive household cleaner can also be used to clean the display and all exterior surfaces. Use a soft microfiber cloth only. Apply the cleaner to the microfiber cloth before cleaning. **DO NOT** use ammonia or acid based cleaners. **DO NOT** use abrasive cleaners. **DO NOT** use paper towels. **DO NOT** apply cleaners directly to the equipment surfaces.

4. Theory of Operation

Carrier Board (PCB-001)

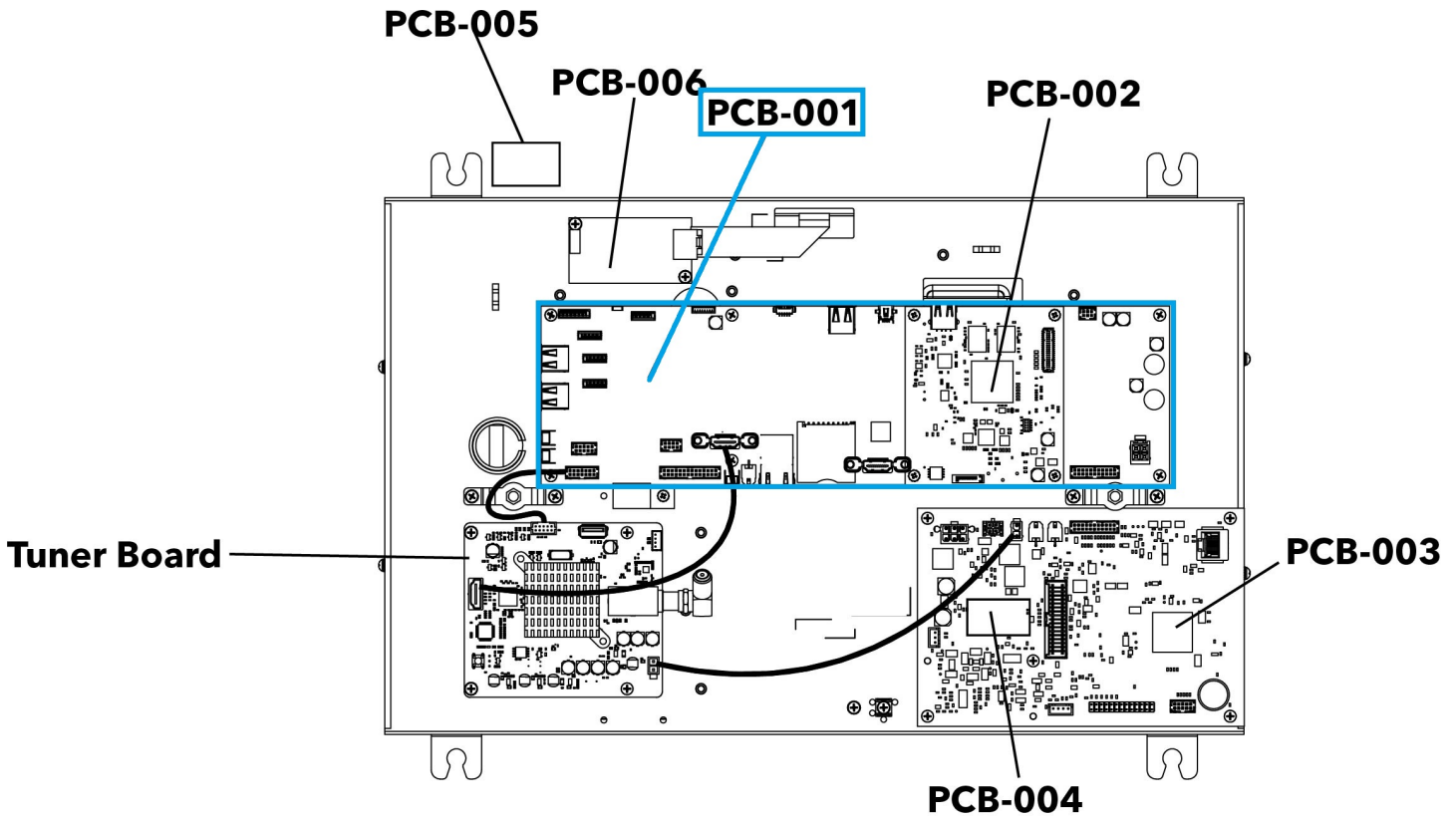

Theory of Operation:

This is the main interconnection board in the console. It interfaces to the various modules in the console. This board should be the last board changed in a Discover console, and only after the remaining systems have been verified to be functional. There might be some differences in how this board connects to the other modules for the various console SKU's, but make sure that all the connectors are properly seated and that there are no pinched cables between any of these connections.

Functions/Connectors:

- The COM board (PCB-002) is mounted onto this Carrier board as a daughter board, and uses three board-to-board connectors between the two boards. Make sure that the spacers between these two boards are properly installed, and that the board is fully seated in the connectors, prior to installing the 4 mounting screws.
- There are two connections to the MIB (PCB-003) board. One cable between P1 on the Carrier board to P1 on the MIB board. The second cable for the 24VDC goes from P6 on the Carrier board to P8 on the MIB board.

Troubleshooting tips:

- The Carrier board does have a USB HUB on it. So failures on functions with some USB tasks (USB reprogramming port, Wireless connectivity module) might indicate that this Carrier board is damaged, but only after you verify the functionality of the other USB modules.
- The Carrier board does contain the EDID firmware, which allows plug-and-play setup with HDMI devices (STB-IPTV, STB on the floor, etc.) since it properly configures the STB output to match our console requirements. All newer Discover consoles include the latest EDID firmware. Contact Life Fitness service call center if there are issues on Discover consoles with video / audio from STB's.

COM Board - IMX6 (PCB-002)

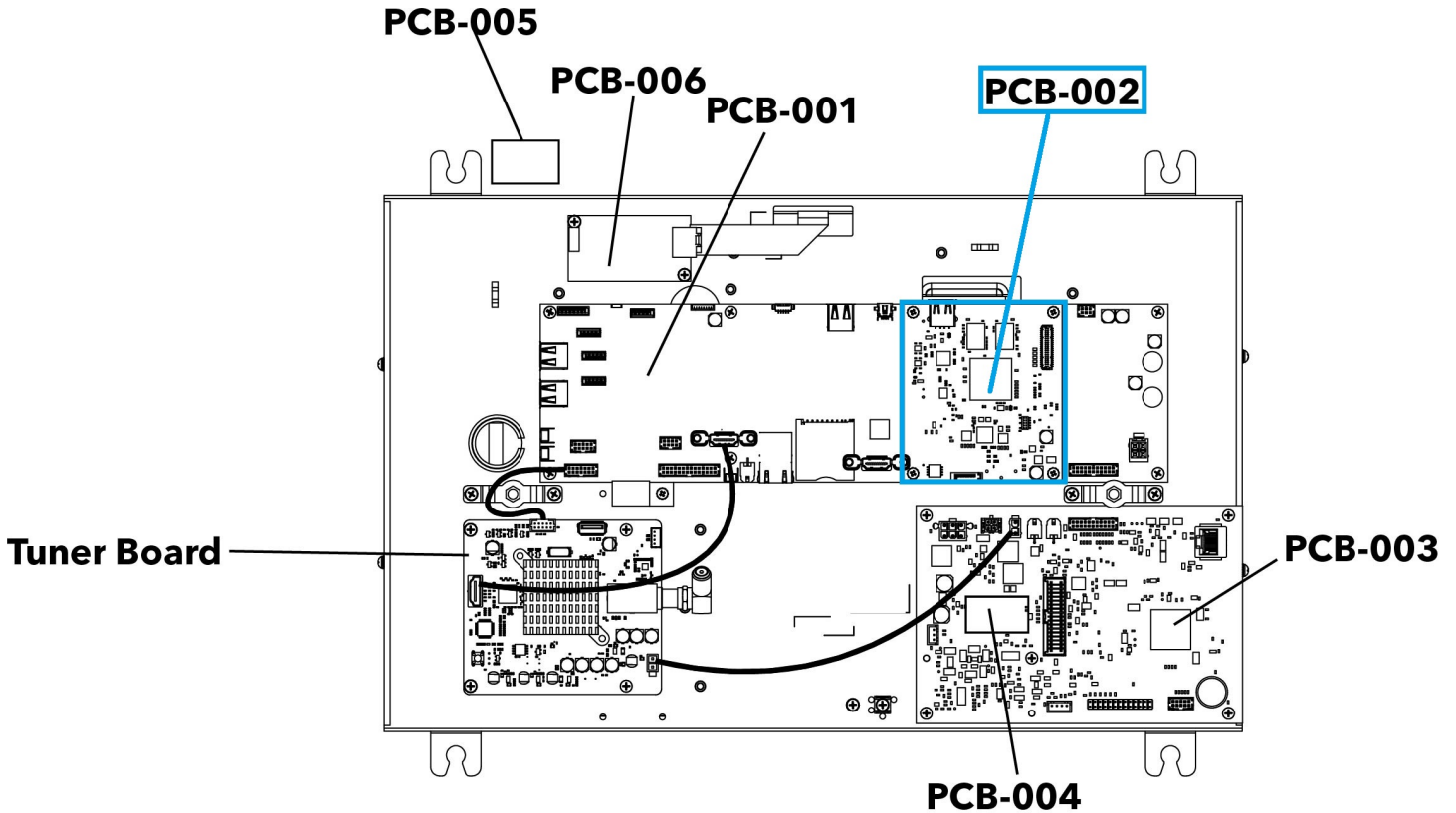

Theory of Operation:

The COM board is the main brains of the console, and interfaces to the other electronic modules for their individual functional needs.

Functions/Connectors:

- The major connection is at the board-to-board connectors between this board and the Carrier board. Make sure that the spacers between these two boards are properly installed.
- The J4 connector goes to the LCD panel.
- The J8 connector is the USB connection to the Touch Screen controller board.

Troubleshooting tips:

- This board is the main brains of the console and contains the majority of the console software, Wireless connectivity drivers, LCD control, Bluetooth drivers, etc.
- In the Discover console design, this board is highly unlikely to be damaged in normal operation.
- This board has the Courses saved on it. If the board is changed for any reason, you must install the original Courses onto this board through the procedure found on LFTechSupport. [Procedure to install original Courses into a Discover Console.](#)
- This board has the OS installed on it. See SD card method recovery procedure in this manual [a48723bcffdd4122aeb33e95a3ff9d14fc08bb9e.ditomap](#) to do a System Recovery.

MIB (PCB-003)

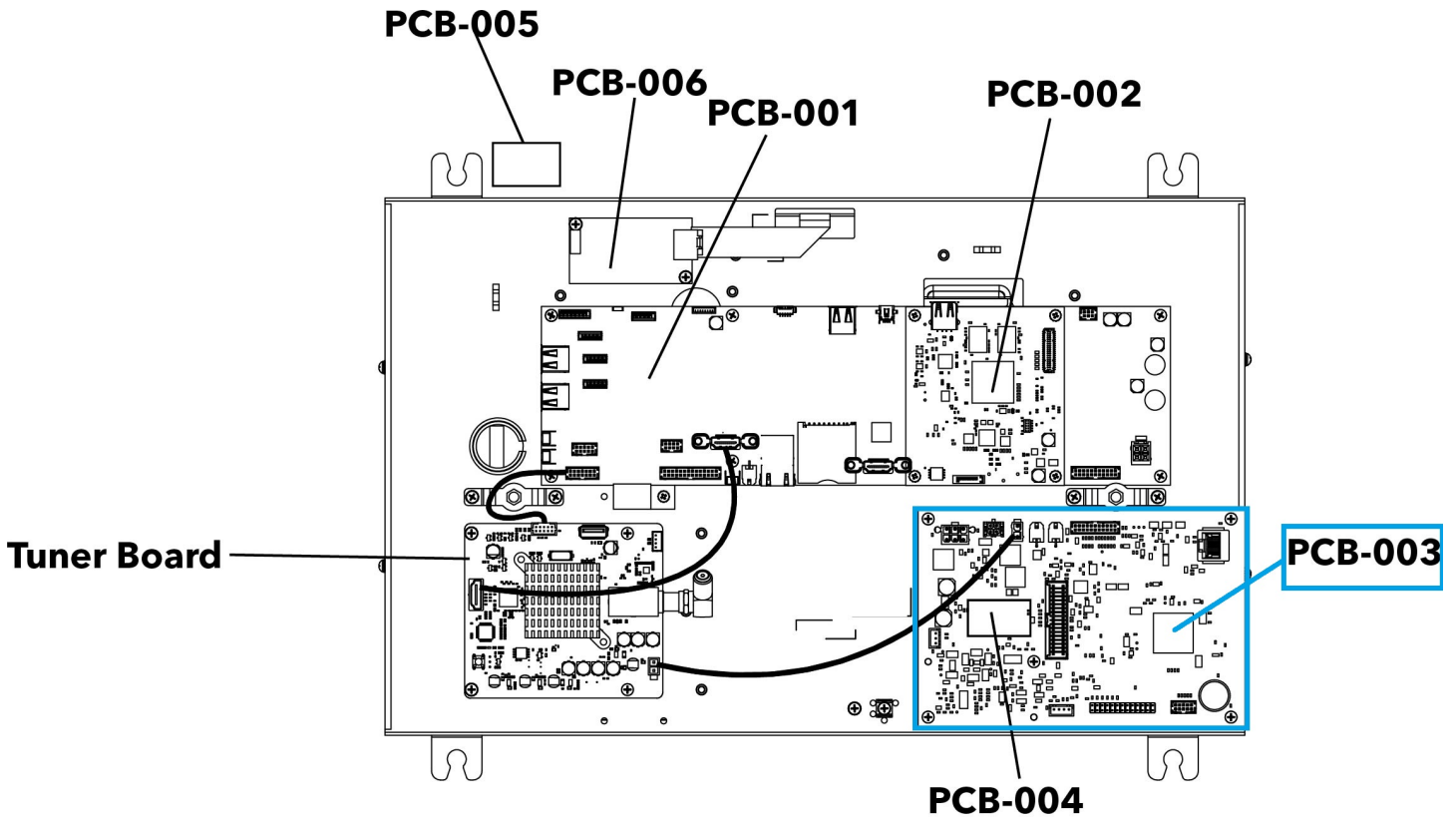

Theory of Operation:

This MIB (Machine Interface Board) is the main interface from the console to the base electronics.

Functions/Connectors:

- The 36 pin connector (P2) has the major connections between the console and base.
- A second connector from the base (P7) brings the main 24 VDC power for the console.
- The P8 connector on MIB provides 24 VDC to the Carrier board (PCB-001).
- The P4 connector is used to provide 12 VDC to the Tuner board.
- The P1 connector is the main interface between the Carrier board and the MIB.
- The P11 connector interfaces to the Polar / Telemetry board. This is located inside the console for Non-Treads.
- The P6 connector is a CSAFE connector only, NOT Ethernet.
- Connector P12 provides the IR signals when "remote control" is required for STB's (such as STB-IPTV).
- Gymkit consoles will have a daughter (Apple) board mounted onto this MIB with 2 screws and spacers. The daughter board is for the Apple interface / authentication and is only present in consoles with Apple cables / dongles. All electrical connections come from the Carrier board (connector P2 on Carrier board).

Troubleshooting tips:

- Communication: The MIB has the hardware to communicate to the base electronics.
- The MIB has a Piezo device which creates the "beeps" in the console.
- The MIB has the circuitry for Contact HR functions.
- The MIB has circuitry to interface to the Activity Zone buttons and the stationary handle (bullhorn) buttons.
- The MIB generates the 12 VDC power needed for the Tuner board.
- The MIB has the power and controls for the CSAFE port.
- The MIB also has some circuitry to interface to the ESS (Emergency Stop Switch). For `Replace E-Stop` errors though, first verify cables, switch, magnet, and Activity Zone before trying a new MIB.

Bluetooth Module (PCB-005)

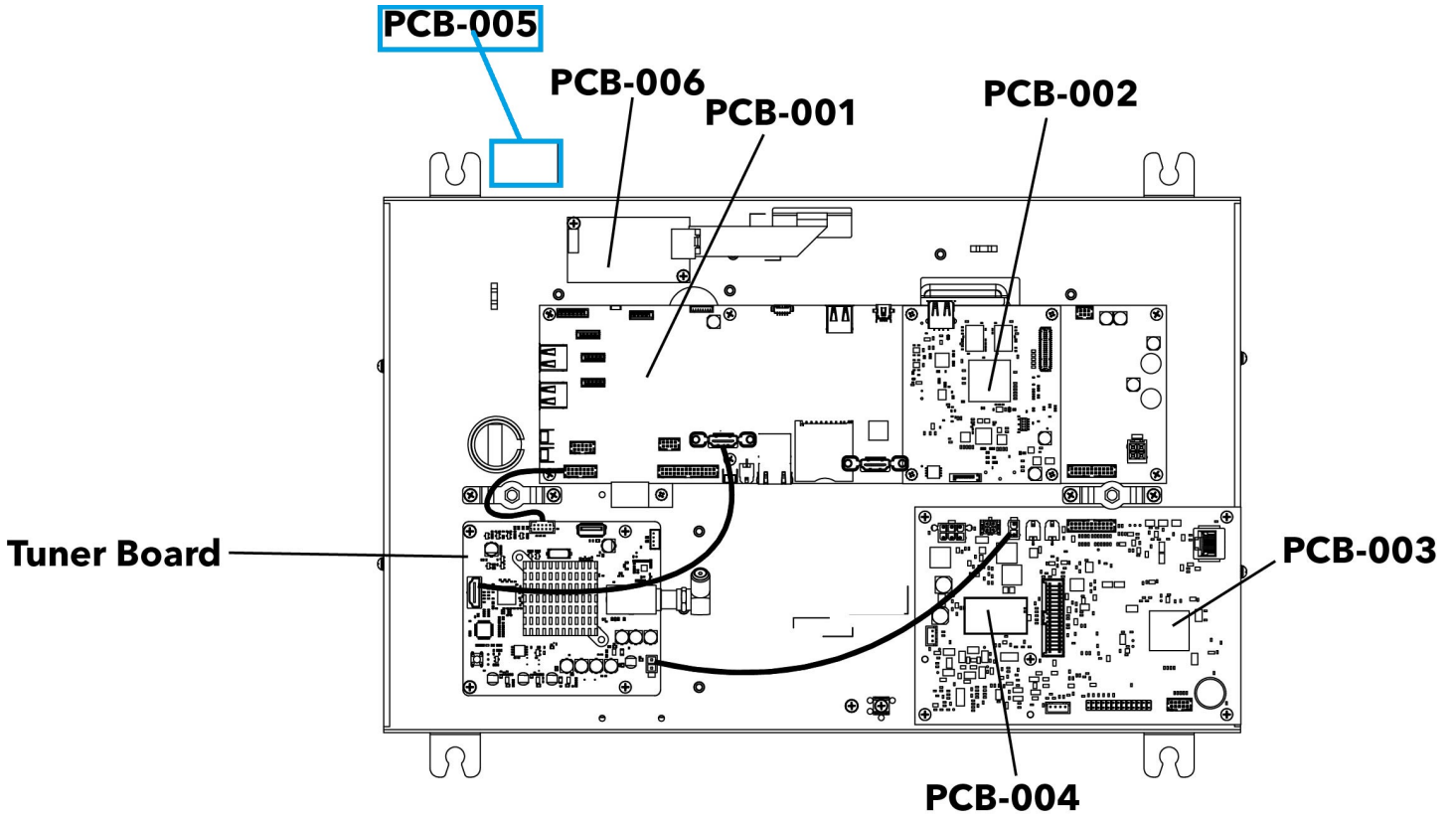

Theory of Operation:

This is a very small board that is stuck with double sided tape and is located on the inside of the front bezel at the top left (when viewing the console from the back with the back bezel off).

Functions/Connectors:

There is only 1 cable (very thin wires) that connects this board to the Carrier board (at connector P16).

Troubleshooting tips:

Bluetooth functionality isolated to hardware is accounted for by this board and its associated cable. Bluetooth software is in the COM board, and is always updated with console software updates.

USB / Headphone Board (PCB-007)

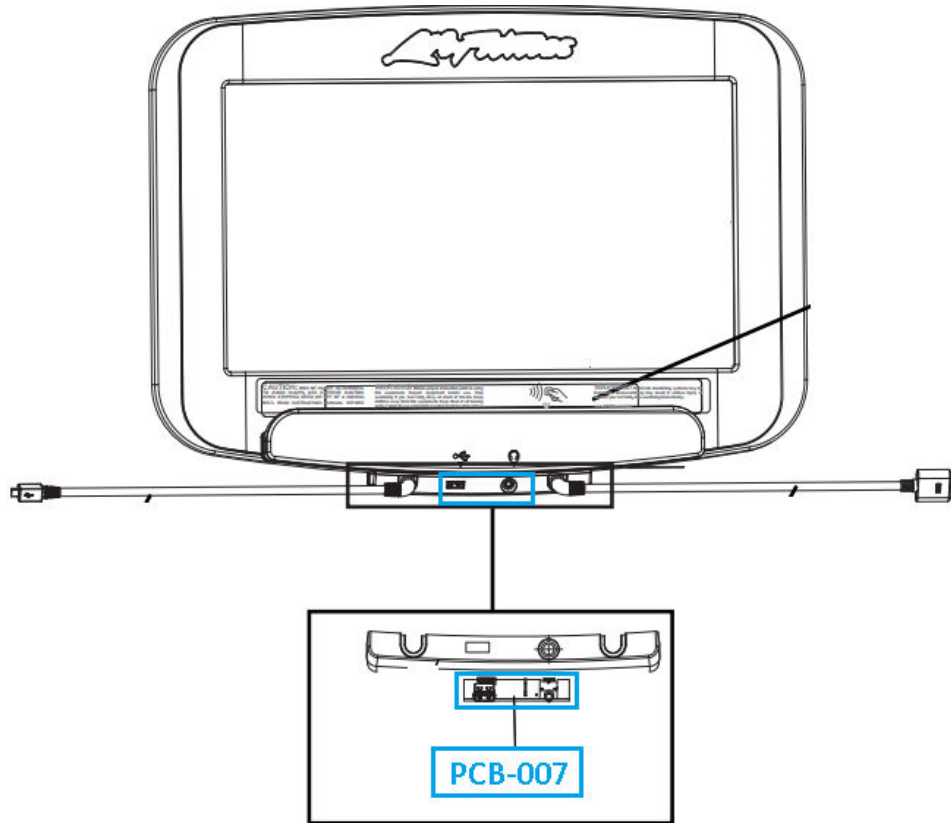

Theory of Operation:

This board is located in the option panel (bottom section) of the console. It houses the headphone jack and the USB port (used for console reprogramming). Please see the Discover Service Parts manual for pictures of this board and its location.

Functions/Connectors:

- The P3 connector interfaces the audio signals to the Carrier board (P28).
- The P2 connector connects the USB port to the Carrier board with a USB micro to USB Type B connector.

Troubleshooting tips:

- This board has the wear and tear items such as headphone jack and USB port, as it is exposed to many insertions and harsh environments.
- Change board for any rusting on the headphone jack or USB port.
- Change board for functional issues such as noisy / no audio in headphones or audio in only one ear.
- Change board if a known good USB stick placed in the USB port is not being recognized by the console.
- Service stock of this board has been replaced with boards containing a "robust" headphone connector to enable longer life for the audio connector.

Apple Authentication Board (PCB-004)

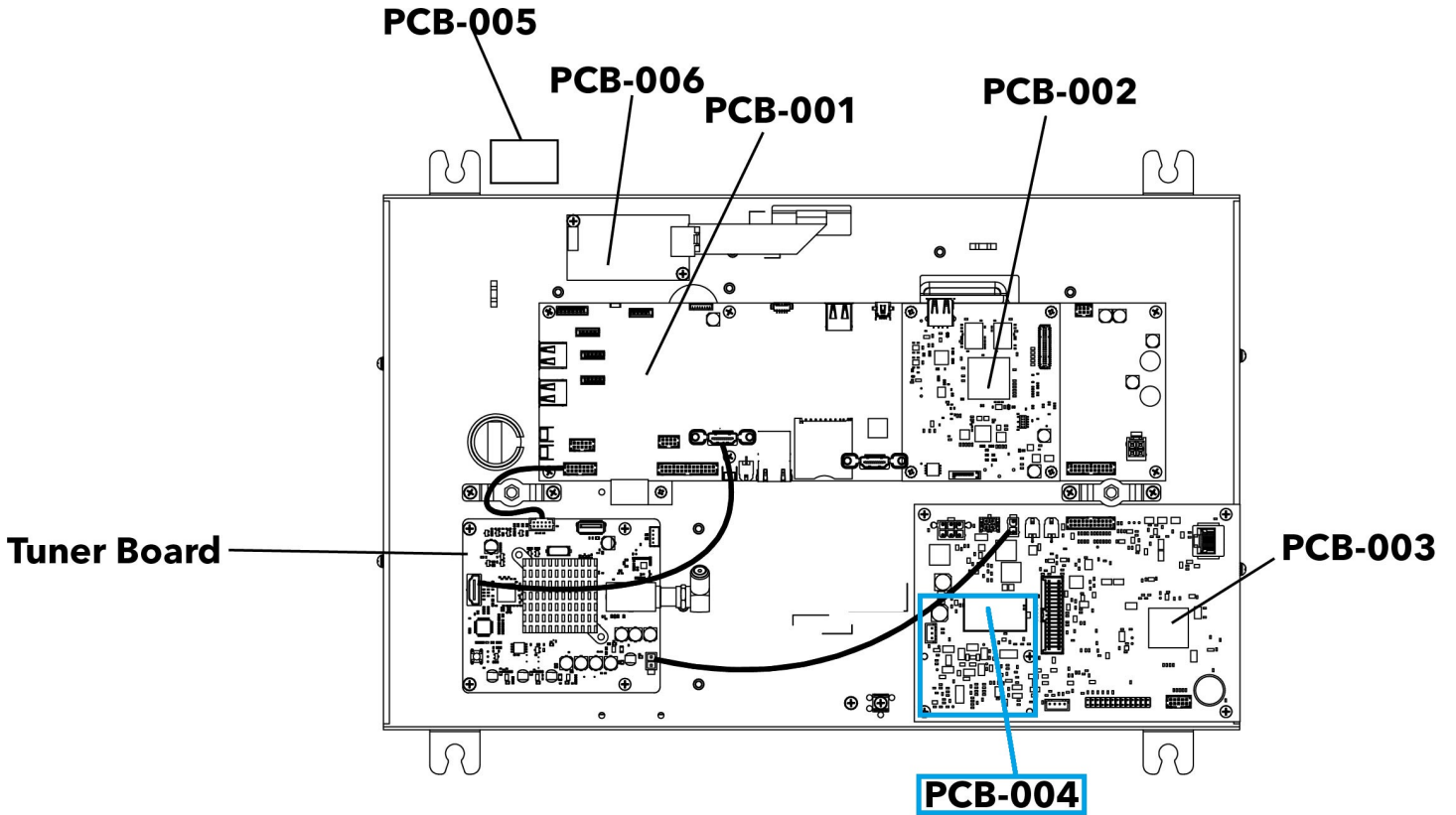

Theory of Operation:

This board is located as a daughter board on the MIB board and is only used for RFID SKU's (Gymkit consoles only).

Functions/Connectors:

The P2 connector interfaces to the Carrier board (P2).

Troubleshooting tips:

This board has Apple authentication hardware, and will only be changed with issues connecting to Apple devices.

Touch Controller Board (PCB-006)

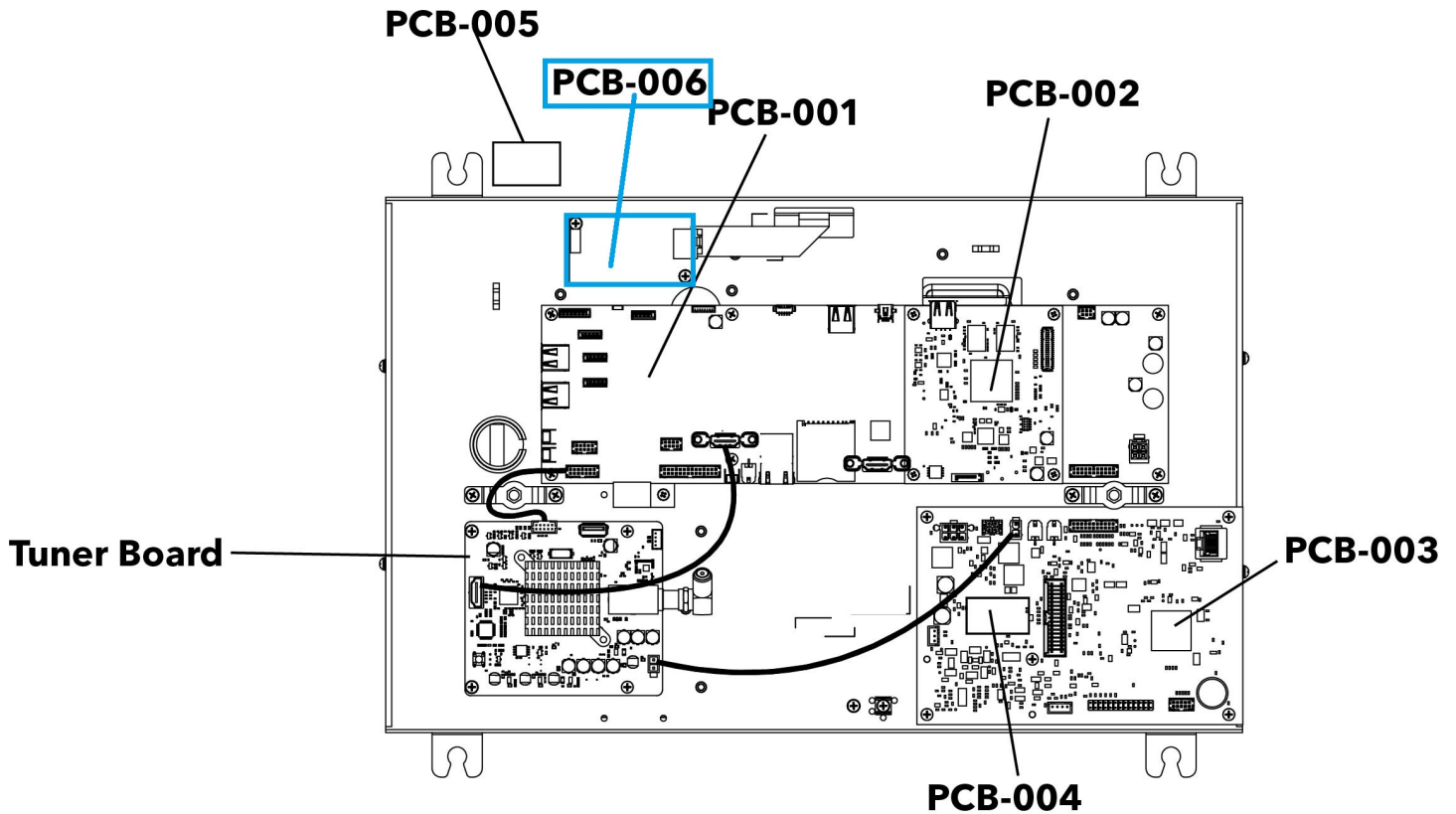

Theory of Operation:

This board is a small board located at the top left of the metal chassis (as viewed from the back of the console with its back bezel removed). This board's only function is to interface to the Touch Screen panel on the front of the Console. The board is calibrated/mated to the Touch screen and should be changed together with the touch screen/LCD panel assembly (per recommendation by the touch screen supplier).

Functions/Connectors:

- The JP1 connector interfaces to the IMX6 COM board (PCB-002, J8).
- The JP2 connector connects to the Touch controller panel through a flex cable.

Troubleshooting tips:

This board might be defective if the Touch Screen is not responding. Note that it must be changed with the Touch screen/LCD panel assembly. It must be purchased in a kit with the Touch screen/LCD panel assembly, and cannot be purchased independently.

Tuner Boards

ATSC, DVB-T2, Pro:Idiom, ISDB-T Japan

NOTE: The STB-SYNC has a Receiver board in this location, and will be described in the "I" section below.

NOTE: See note on Open-IPTV, which has no board in this Tuner board location.

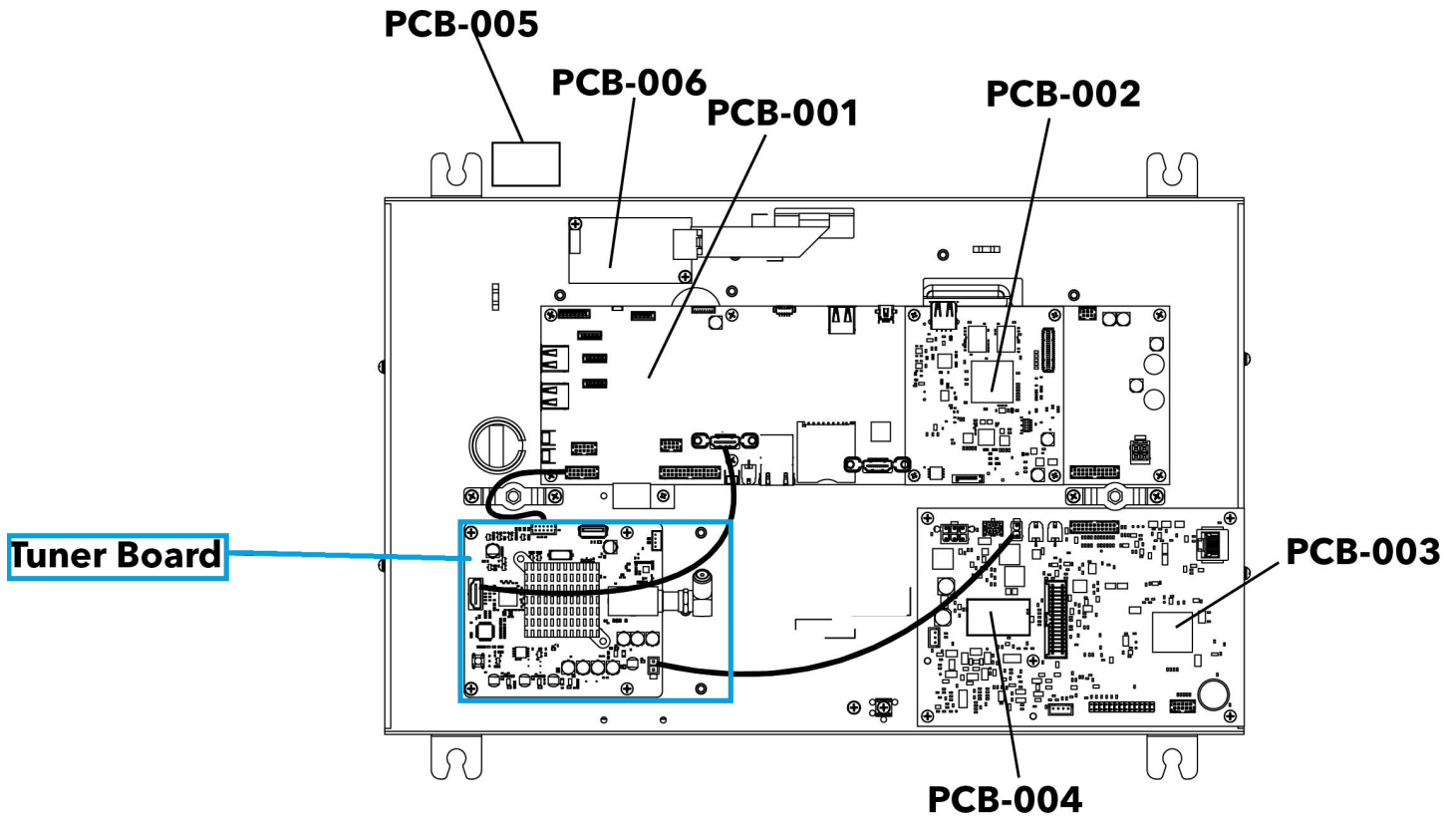

Theory of Operation:

A Tuner board is required to allow the console to receive RF based TV (video / audio) signals and is different for the various regions depending on the facility / country infrastructure and signal types (ATSC / NTSC / DVB-T2 / PAL / Pro:Idiom / etc.). The various tuner boards use HDMI output to connect HDMI IN on Carrier board (PCB-001).

Functions/Connectors:

- For the HDMI tuner boards, the tuner output is a HDMI cable to HDMI IN at the Carrier board. The communication and audio signals are through a second cable from the Tuner board to the Carrier board (P4).
- Power to all types of Tuner boards is 12 VDC and comes from the MIB board (P4) connector.
- The TV signal into these consoles is through a coax cable, and connects into the appropriate RF Type F connector on the Tuner board.

NOTE: The Open-IPTV console will not have any board in this Tuner Board location, and instead brings the TV signals through a CAT6 / Internet cable plugged directly into the Ethernet port (P9) on the Carrier board. The setup of these consoles is extremely dependent on the customer's infrastructure.

Troubleshooting tips:

- The Tuner boards have their own software and need to be updated separate from console software. The tuner boards will need software updates if there are issues with Tuner functions or to keep all Tuner boards at the same revision to allow proper LFconnect interaction. Follow the appropriate software update procedures on LFTechSupport.com for the Tuner board that you have.
- Many issues have been identified and corrected, and most are solved by installing the latest software into the Tuner board. Always verify that the latest version is installed before troubleshooting further.
- Tuner channel lists for all tuners can be uploaded and downloaded from LFconnect. Note that this will only work for tuners of the same type and software revision. Therefore, if a location has a mixture of tuner types, only one of these types can be managed through LFconnect. The "different" tuner type(s) will need to be manually scanned and then use USB "import / export" functions to "Clone" the channel list into other tuners of the same type.

- The Tuners are dependent on the customer infrastructure setup, and should follow the guidelines provided to sales for the Audio / Video codec's supported, etc.
- For Open-IPTV consoles, most issues were identified with Infrastructure setup, and will require the assistance of the IT department at the location to verify that they are meeting the *Life Fitness* requirements for these consoles. It has been recommended to Sales that at least one of these consoles should be "tested" at the customer facility prior to setup of a complete workout center to validate the more complicated infrastructure requirements, and make the adjustments necessary for proper TV signals into the Discover console. As with all other consoles, always verify the latest software is in the console prior to further troubleshooting.

STB-SYNC Receiver Board

Theory of Operation:

The STB-SYNC console brings in the signal from a STB in the facility through a CAT6 cable after it is converted from an HDMI signal (at the STB) using an IPTV Transmitter Kit. The IPTV Receiver board, inside the console, then converts this CAT6 input from the IPTV Transmitter kit back into a HDMI signal and provides it to the Carrier board. This STB-SYNC Receiver board is setup differently than the Tuner boards (like ATSC, DVB-T2, etc.) but has the same function of allowing the user to watch TV on the Discover console.

Functions/Connectors:

- For the STB-SYNC consoles, the audio/video signals are through a HDMI cable to the Carrier board HDMI connector (HDMI IN). The remote control operations are through an IR cable from connector P12 on the MIB board.
- Power is 5VDC and comes from the Carrier board (P8) connector.
- For the STB-SYNC console, the TV signal is from a CAT6 cable that plugs into the IPTV receiver board (Ethernet IN connector). If this console is also setup for wired internet, then there will be a short Ethernet cable between the OUT connector of the IPTV Receiver board and the Carrier board Ethernet connector (P9). Leave this short Ethernet cable disconnected at one end if this customer is using Wireless Internet, as this cable is not needed then but can cause consoles errors.

NOTE: The Open-IPTV console will not have any board in this Tuner Board location, and instead brings the TV signals through a CAT6 / Internet cable plugged directly into the Ethernet port (P9) on the Carrier board. The setup of these consoles is extremely dependent on the customer's infrastructure, and the published guidelines must be followed for proper setup of this product.

Troubleshooting tips:

- For setup of the STB-SYNC consoles, if the TV video is not present, verify that the output of the STB (facility) is at 720P resolution. If it cannot be manually set at the STB, then the EDID file on the Carrier board might need to be updated (as also noted in Carrier Board section). If you believe that you need the EDID file updated, please contact *Life Fitness* Customer Service.
- If the issue with the setup is that the channels do not change, then it is most likely related to the IR functions. First verify that you have selected the correct STB manufacturer and part number in the Console System Options. Next, verify that the IR Blaster is properly mounted to the STB (IR receiver) as there have been instances where this has fallen from the STB or is not mounted in the correct position. Lastly, verify internal to the console that the IR cable (2 wire) is connected from the MIB to the IPTV Receiver board.
- As previously stated, always verify that the proper recommendations were followed with setting up the STB-SYNC consoles as this should correct most issues being experienced at a facility.

Wireless Connectivity Module

Theory of Operation:

The Wireless Connectivity Module is used in a Discover console to allow the console to access the internet through Wireless Connectivity Access Points (AP). The Module is mounted on the top right corner of the Discover Console (when viewed from the back with the back plastic removed). Please see the documents on LFTechSupport (snapshot below) for further details.

Functions/Connectors:

- The only function of this module is to provide access to a Wireless Connectivity access point.
- The cable is a USB to USB cable, and connects to the Carrier board.

Troubleshooting tips:

- Some items are covered in the Troubleshooting section of this manual. See [Internet Issues at the Console](#).
- Extensive documentation is already created on the Module's connections, installation procedures, setup, etc. and published on LFTechSupport. Please reference these for further information on these modules

RFID Module

Theory of Operation:

The RFID module is used in a Discover console to allow interface to various RFID products (key fobs, cards, etc.). This module is an optional module and can be ordered with any Discover SE3HD console.

Functions/Connectors:

- The only function of this module is to allow RFID functionality in the Discover console.
- There are some specific connections and routing of cables for the RFID module, and are all described in the documents already posted to [LFTechSupport](#). Please review documents on [LFTechSupport](#) (as highlighted below).
- This RFID module is located in the reading rack of the console. This location was chosen for more reliable (smaller distance) activations between the RFID module and the customers RFID products.

Troubleshooting tips:

- Retrofit instructions for the RFID module are posted on [LFTechSupport](#). There will soon be updates to include the new installation location in the reading rack. If there are any issues, first make sure all the steps in the procedure are followed and all the cable connections are properly made. If issues persist, contact *Life Fitness* Customer support for further assistance.
 - [Retrofit Assembly Instructions RFID Module Discover Non-Treadmill](#)
 - [Retrofit Assembly Instructions RFID Module Discover Treadmill](#)
- For setup of the RFID see [RFID Setup and Verification Guide for Discover Tablet consoles](#) posted to [LFTechSupport](#).
- There have been some reports of "Audio noise heard in the headphones" when plugged in the headphone plug of the console. This was isolated to the routing of the RFID cables, specifically the audio wires (twisted pairs to Headphone / USB board) and the power cable to the RFID module. Those will need to be separated or a ferrite use to negate the noise. See Service Bulletin [Discover RFID console with Audio Noise using headphones](#) on [LFTechSupport](#) for more info.

5. How To's

Knowledge Base

See [Knowledge Base](#) for more detailed information.

How to Clone TV tuner settings through USB

NOTE: This procedure enables one console to be programmed to the customers liking (channel names, etc) and then copied into the other consoles quickly.

1. Choose the console that will be used for doing all the programming of the tuner channels as desired. This console should be scanned in the TV Setup and the channels named as desired. This console must also perform a **Create Channel List** in the TV Setup to ensure that the GUI also is populated with the proper channel list.
2. Go into **System Options > Configuration > Export / Import Settings.**

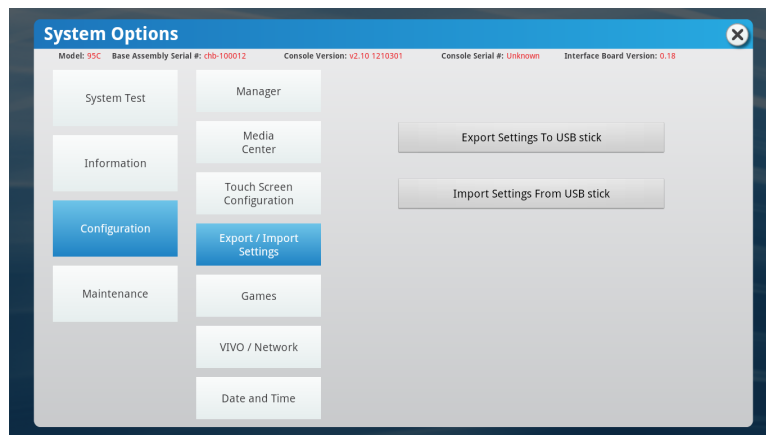

3. Plug in a USB stick (preferably blank) into the USB port of the console.
4. Press **Export Settings to USB stick.** You will see the message below for a short time.

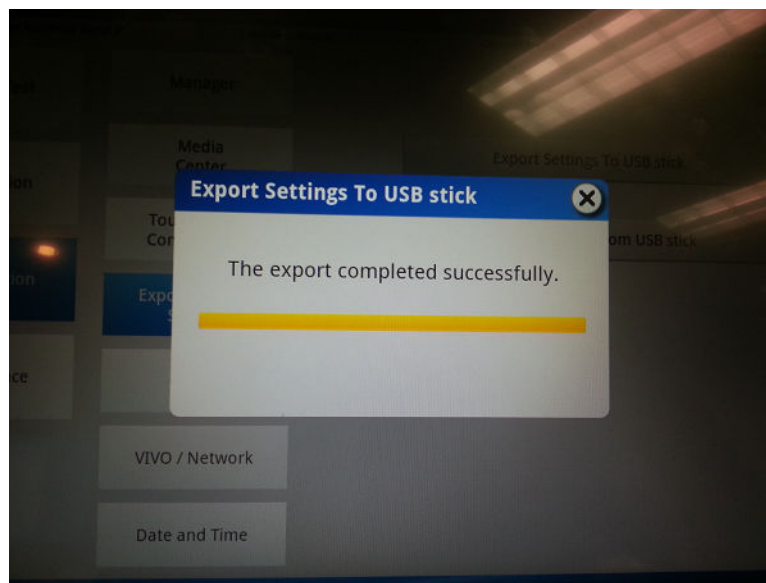

5. If the USB stick already has an export file, the following message will be displayed. Press **Yes**.

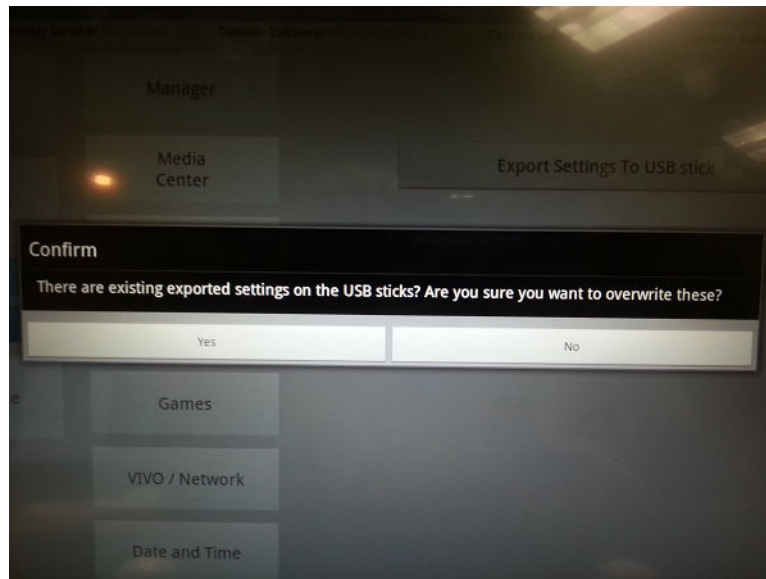

6. Once the file is on the USB stick, it can be used to "clone" other consoles for the Tuner settings of the first console.
7. Plug USB stick (with the exported file from the first console) into the console that needs the Tuner settings
8. Go into the same screen as shown in step 2 (Export / Import Settings).
9. Press **Import settings from USB stick**. You will see the message below during the programming.

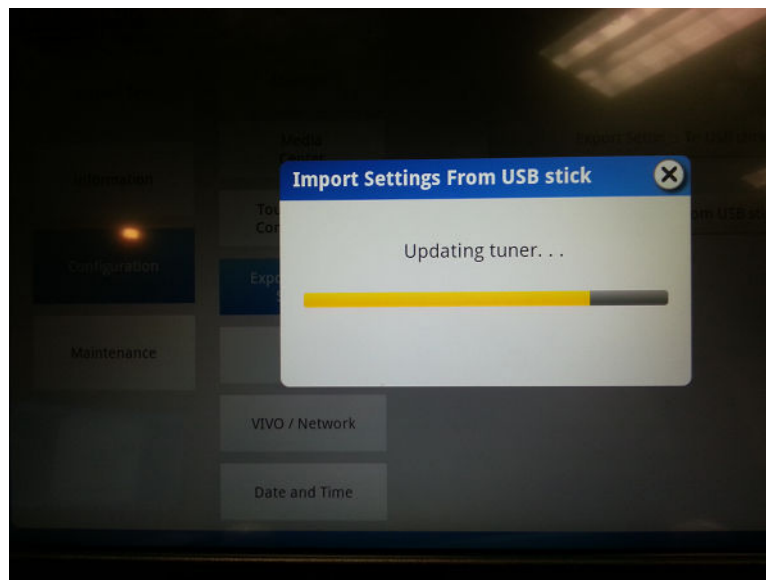

10. When this is complete, the second console will have the same Tuner settings (channels, etc.) as the first console.
11. Repeat steps 7-10 for all consoles that need to be cloned.

How to Calibrate the Touch Screen

1. Go into **System Options > Touch Screen Configuration**.

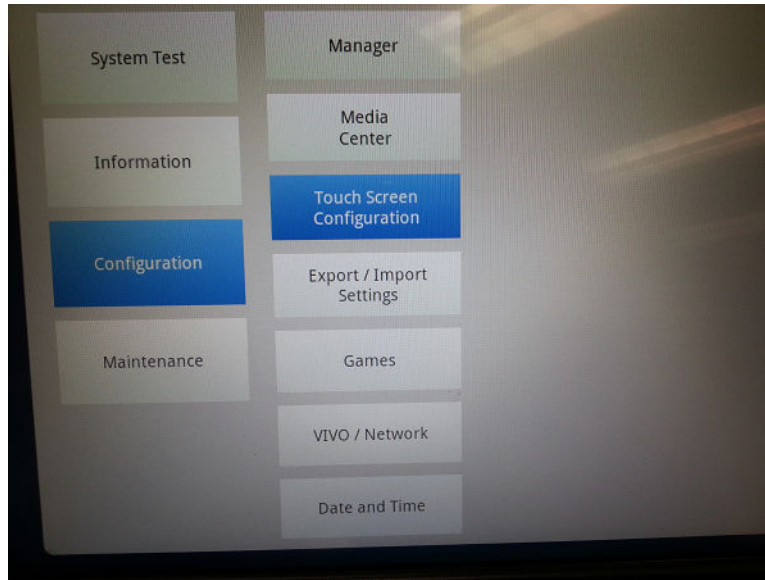

2. Tap **Touch Screen Configuration** button. The following screen will be displayed:

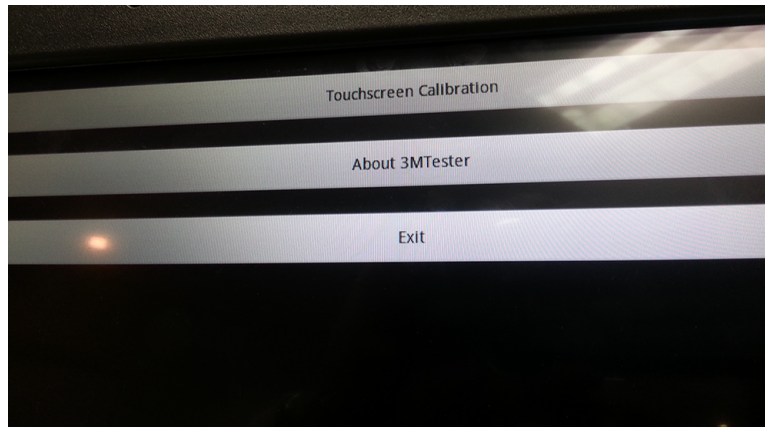

3. Tap **Touchscreen Calibration** button at the top of the screen.
4. The screen will blank out with a GREEN circle shown at the bottom left. Press and hold the location of that button for 1-2 seconds and then release.
5. The button that was just pressed will change to RED, and another GREEN button will be displayed in the top right of the screen.
6. Press and hold the GREEN button (top right) for 1-2 seconds and then release.
7. The next screen will be the **Touchscreen Calibration** screen pictured in step 2 above.
8. The Touch Screen calibration is complete. Tap the **Exit** button.

How to extract LOG / Information from console

Purpose: Consoles have the ability to create and save the software log files from the consoles onto a USB stick for troubleshooting software related issues.

Background: Gather as much history on the “problem” console (serial number, problem description, sequence to repeat issue, etc.) first. This ensures that the logs gathered can be properly analyzed in determining the root cause of the failure. In general, when there are any console related issues, please detail the issue and gather this software log file through the USB port.

Procedure: Follow the steps below to collect the console software log.

1. Create a text file called `collect_logs.txt`. This file can be blank or contain any characters, it is the name that is important. This file can be created with Notepad or other such text editor program.
2. Copy the `collect_logs.txt` file to the root directory of a blank USB stick. The USB stick can be between 512MB-16GB.

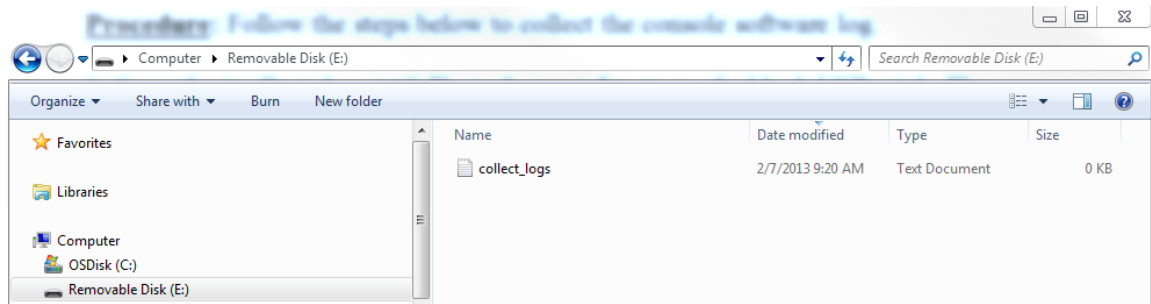

3. Plug the USB stick into the USB port (option panel) of the console.
 - If possible, do this before power cycling the product as information is lost when powered down.
 - The trigger to download a log file is to plug in the USB stick. If you plug in the USB stick, remove it after a few seconds, and then plug it back into the same console again, 2 different log files will be generated since there were 2 USB insertions.
 - The same USB stick can be used to collect logs from multiple consoles.

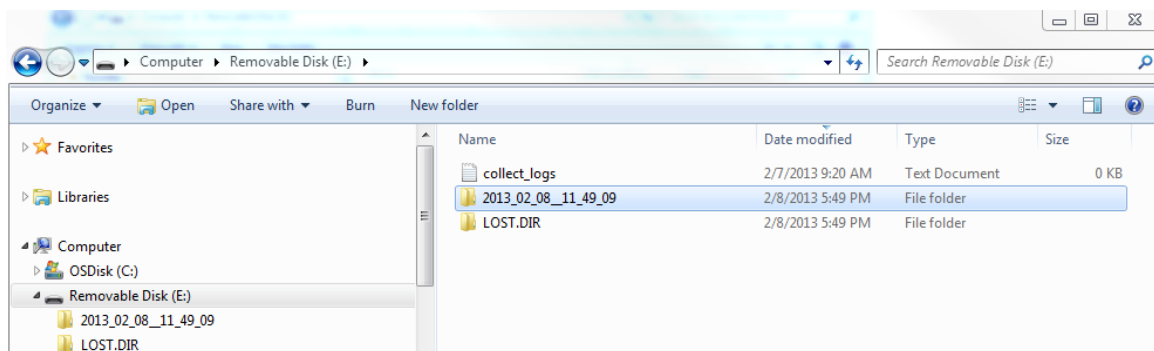

4. Keep the USB stick connected for 15-30 seconds and then remove from console. The logs will be collected even though there is no message shown on the console. Folders are automatically created as needed.
5. If requested, send the log files / folders along with detailed history of the console to *Life Fitness* Customer Service for analysis and future product improvements.

6. Troubleshooting

Knowledge Base

See [Knowledge Base](#) for more detailed information.

Troubleshooting

Malfunction	Probable Cause	Corrective Action
No Power.	ON / OFF switch is not in proper position.	Turn the switch to the ON position.
	Power source is insufficient.	Plug treadmill into a dedicated 20 amp circuit. Using a voltmeter, verify power at outlet. If no power exists, reset circuit breaker at panel.
	Line cord is damaged.	Replace line cord. Contact <i>Life Fitness</i> Customer Support Services.
	Line cord is improperly seated in socket.	Inspect power connection at wall outlet and at machine for proper contact.
	NOTE: International Platinum Club Series Treadmills (PCST) only: You may be in "Energy Saving Mode".	Treadmill will go into Energy Saving Mode after 5 minutes of inactivity. To wake up the console, step on the treadmill belt. The treadmill will automatically wake up and the console will light up. Waking up the treadmill takes approximately 50 seconds after stepping onto the belt.
NOTE: International Platinum Club Series Units only (PCSC, PCSR, PCSX): You may be in "Energy Saving Mode".	Unit will go into Energy Saving Mode after 5 minutes of inactivity. To wake up the console, pedal until you hear a beep. The unit will automatically wake up and the console will light up. Waking up the unit takes approximately 50 seconds after beginning to pedal.	
Treadmill striding belt slips off-center.	Floor surface is uneven.	Check levelers and level treadmill. Check striding belt and re-tension as necessary. Refer to Assembly Instructions.
Maximum treadmill speed is reduced.	User is pushing striding belt. This occurs when the runner is running faster than the striding belt will travel, with the result of the striding belt being pushed with the runner's feet.	Instruct users not to push striding belt in either direction.
	User is stalling striding belt. This will occur with heavier users at lower striding belt speeds. The striding belt will "stall" if the user is traveling slower than the striding belt speed.	
	Striding belt/deck malfunctions. The deck laminate is worn through or the underside of striding belt is glazed over (hard, glossy).	Replace belt and deck. Contact <i>Life Fitness</i> Customer Support Services.
	Power source is insufficient.	Plug treadmill into a dedicated 20 amp circuit.
Rubbing sound comes from underneath treadmill.	Foreign objects may be stuck underneath the machine.	Inspect underneath striding belt and machine. Remove any debris or objects that may cause interference with the treadmill.
Display does not illuminate when machine is powered on.	Loose connection at display console or motor control board.	Check all electrical connections for proper attachment. Contact Customer Support Services.

Troubleshooting - Heart Rate Reading

Malfunction	Probable Cause	Corrective Action
Heart rate reading is initially detected and functioning normally but then is lost.	Use of personal electronic devices, such as cell phones and portable MP3 players, causes external noise interference.	Remove the source of noise or reposition the exercise equipment.
	Equipment is in close proximity to other sources of noise such as audio/video equipment, fans, two way radios, and high voltage/ high current power lines.	
Heart rate readings are abnormally elevated.	Television sets and/or antennas, cell phones, computers, cars, high voltage power lines, motor driven exercise equipment , and another heart rate transmitter within 3 ft. (0.9 m) generate electromagnetic interference.	Move the product a few inches away from the probable cause, or move the probable cause a few inches away from the product, until the heart rate readings are accurate.
Heart rate reading is erratic or absent entirely.	Belt transmitter electrodes are not wet enough to pick up accurate heart rate readings.	Wet the belt transmitter electrodes (see Optional Polar Telemetry Heart Rate Chest Strap).
	Belt transmitter electrodes are not laying flat against the skin.	Ensure the belt transmitter electrodes are laying flat against the skin (see Optional Polar Telemetry Heart Rate Chest Strap).
	Belt transmitter needs cleaning.	Wash the belt transmitter with mild soap and water.
	Belt transmitter is not within 3 ft. (0.9 m) of the heart rate receiver.	Make sure the chest strap transmitter is within 3 ft. (0.9 m) of the heart rate receiver.
	Polar telemetry heart rate chest strap battery is depleted.	Contact <i>Life Fitness</i> Customer Support Services for instructions on how to have the Polar telemetry heart rate chest strap replaced.
	Polar telemetry heart rate chest strap did not lock in with the heart rate receiver.	<p>Make sure the Polar telemetry heart rate chest strap is properly attached to the user's chest and move closer to the heart rate receiver inside the console. Wait up to 10 seconds for the heart rate to display on the console. The overall range of the heart rate strap is approximately 3 ft. (0.9 m) after it communicates with the receiver. The strap must be 1.5 - 2 ft. (0.5 - 0.6 m) away from the receiver in order to start communicating. When the display shows a heart rate value stay within 3 ft. (0.9 m).</p> <p>Notes:</p> <ol style="list-style-type: none"> 1. Ensure proper adherence of the Polar telemetry heart rate chest strap to user's chest. 2. Ensure proper conductivity between the electrodes and user's chest. 3. If needed, use the Polar watch to verify chest strap's operation.

Troubleshooting - Life Fitness On Demand™

Malfunction	Probable Cause	Corrective Action
Life Fitness On Demand library is not displaying.	Life Fitness On Demand has not been activated.	Activate Life Fitness On Demand via Manager's Configuration or on Halo.Fitness .
	Equipment is not connected to the internet.	Check network connectivity in Manager's Configuration. Use network speed test on console to verify that your facility has 2.5 Mbps of bandwidth per unit.
Life Fitness On Demand videos are lagging or choppy.	Insufficient internet bandwidth.	Disable Life Fitness On Demand on select number of units to reduce bandwidth strain. Refer to Minimum Download Bandwidth Requirements for specifications.
	Unit requires reboot.	Restart the unit. For optimal functioning, enable Nightly Reboots in Manager's Configuration.
Poor audio quality.	Weak wired headphone connection.	If using wired headphones, ensure proper connectivity within headphone jack. Small adjustments in jack placement should produce crisp and clear audio.
	Bluetooth pairing malfunction.	Unpair and repair Bluetooth headphones with the console. Follow the prompts on screen.

No Power at Console

The only difference when troubleshooting the Discover bases vs. the previous Elevation (Engage/Inspire) series bases, is that the Discover base has a 24 VDC brick style power supply for all Discover consoles. There are no Stand-alone units as we have had in past products.

- Verify proper power to product. Check cables and other items as has been done with previous products.
- Is there anything seen on the console? If not, is there beeping when the power is applied to the product. Check that power is good all the way up to the console.
- If more than one console is available, then try to troubleshoot by swapping a console. If the issue is isolated to the console, then replace console.
- Isolate base from console.

Wireless Bluetooth Headphones

- The Bluetooth headphone must be capable of A2DP profile.
- Make sure that **Wireless Devices** is **ENABLED** in System Options / Configuration / Wireless Devices.
- Once properly setup, there will be a **Wireless** Icon that shows up.

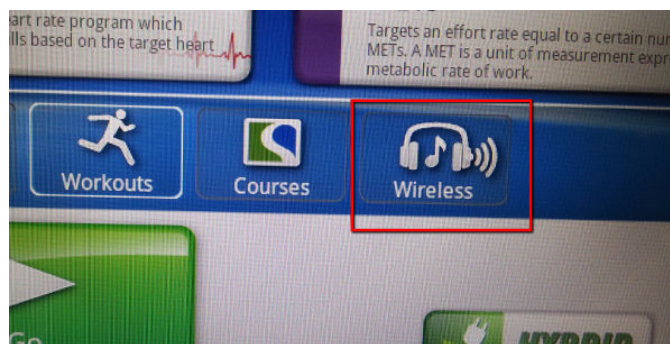

- The Bluetooth headphone must be paired with the console properly. First get the headphone in Discoverable mode (per headphone user manual), then press the **Wireless** icon on the console. You should see the following screen with the Bluetooth device listed.

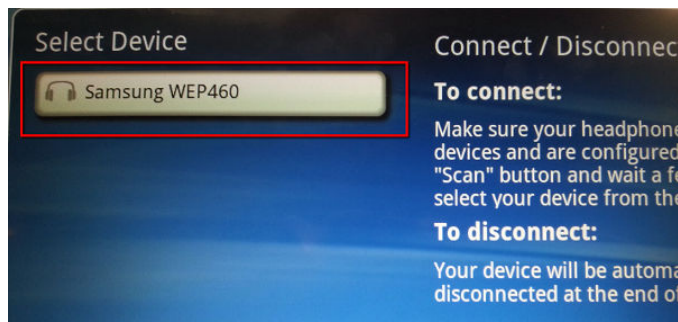

- If successful in pairing, your Bluetooth headphone is ready for use with the Discover console.
- If the headphone is NOT compatible with the Discover product, there will be a message that flashes on the screen `This type of device is not supported.`



Internet Issues at the Console

Common for Wired and Wireless

- Review the FAQ's for Network requirements of the console. Verify with the IT department at the facility that these requirements are being met (no proxy, dynamic IP address, required open ports, etc).
- Identify how many consoles are without Internet connection. If more than one unit or the whole facility, then there is a possibility of a router or Internet issue with the facility and not the product.
- Power cycle the product first before any further troubleshooting. If the router at a facility is reset for any reason, the consoles will also need a power reset. The console identifies an IP address on power up.
- Check **Date and Time** in System Options / Information. Verify correct Time Zone, Date, and Time for equipment location.
- Is there an **Internet** icon displayed at the console? If there is an Internet icon but the console cannot access the internet, there is most likely an issue at the facility (such as a firewall, etc.) as described in the FAQ's.
- Verify that the IP address does not start with 169-. The IP address of the console can be found in System options / Information / Network Info (last item in menu). This 169 address indicates an issue at the facility with connection to the internet at that port.
- If the Internet icon shows up but none of the quick-links for Internet sites work, then go to the Internet browser page and type in a known site's IP Address in the address bar. For example, type in `74.125.225.176` into the internet address bar. This is the home page of www.google.com. If typing in this IP address gets to the Google site, the issue is most likely with the DHCP server at the facility.
- There have been a couple instances where the DHCP server at a facility "ran out" of IP addresses. This would cause one or a few units to not have internet connectivity. Verify with the units that don't have internet, whether they have IP addresses in the System Options / Information / Network Information section. If no IP address on a few units, there is most likely a facility issue with their DHCP server.

Wired only

- If no IP address shown under Network Information, first try a power cycle to the product. If there is a glitch with the facility router that caused it to lose the IP address, the console requires a cold re-boot to recover the IP address. The other items to verify are the Date / Time of the console and the router and the Ethernet connection itself.
- Anytime Ethernet cables are connected or disconnected, a power cycle to the product / console is recommended.
- Verify that the Ethernet cable coming to the product functions as expected. This can be verified by connecting this Ethernet cable to the technicians laptop (**Wireless LAN** turned off) and having the laptop connect to the Internet (without having to set proxy's, IP address, etc) by verifying access to some internet sites (like LFconnect.com, etc). Note that the laptop should be one that does not belong to this facility so it confirms that there aren't any proxy setups already programmed into it.

- Verify if the Ethernet cable (in the base) is connected to the Ethernet connector at the console (see Installation instructions for more details).
- Verify the Ethernet cable in the base by connecting the Ethernet cable from the facility directly to the Ethernet port at the console. If the cable is not long enough to reach the console, a shielded CAT5e coupler and additional CAT5e/6 cable will be needed to verify this.
- Try to connect the product directly to the Internet source (Gateway/Modem) to isolate if the issue is with the facility setup (like the Network switch, etc.).
- If the Network switch is a managed style, it is possible that it was not properly setup as an un-managed switch. This can be verified by using a simple un-managed switch (example Netgear #FS108) to see if the console can now connect properly to the internet.
- If the customer is using a Cisco Catalyst Network switch, and the console software is at V2.18 or earlier, then make sure that "spanning-tree portfast" is **ENABLED**. See following URL for more info: http://www.cisco.com/en/US/products/hw/switches/ps708/products_tech_note09186a00800b1500.shtml

Wireless only - Standard Protocols

- Reference [Wireless Connectivity Setup and Verification Procedure for Discover Tablet Consoles](#) for further details with screen shots for the various Wireless Connectivity setups. The document is posted on [LFTechSupport.com](#).
- **No Connection:**
 - Is Wireless Connectivity Module (in the console) **ENABLED** within System Options / Configuration / Wireless Connectivity?
 - If **ENABLED** but there is no results from the access point **Scan**, then the issue is either a bad Wireless module in the console or the access point is down or out of range.
 - Is the Wireless Access point powered properly? POE? Power adapter?
 - Verify power on Router and Modem (from ISP).
 - Power reset on the Console, Wireless Access Point, Router, and modem.
 - If no IP address shown under Network Information, first try a power cycle to the product. If there is a momentary communication fault with the facility router or wireless access point that might have caused it to lose the IP address, the console requires a cold re-boot to recover the IP address. The other items to verify is that the wireless module is **ENABLED** and set at the proper frequency band (in System options), the Date / Time of the console and the facility router are set correctly, and the console is in range of the appropriate wireless access point.
 - Verify proper **Username** and **Password** (in the System Options of the console) credentials for the Network connection.
 - Have the products, that do not have Internet access, changed location since initially installed? If so, check the signal strength on the console to be **good** or **excellent**. If **poor**, then you might need to rearrange access points to provide adequate coverage.
- **Slow Connection:**
 - Hard reset on the Console, Wireless Access Point, Router, and modem.
 - If all units have slow Internet access, then verify that the minimum Internet connection speed (provided by ISP) is met. Bandwidth specified by *Life Fitness*: 4 Mb/s for up to 8 units and 0.5 Mb/s for each additional product.
 - Have the products, that do not have Internet access, changed location since initially installed? If so, check the signal strength on the console to be **good** or **excellent**. If **poor**, then you might need to rearrange access points to provide adequate coverage.
 - Check that the access point settings do not limit the bandwidth per unit below 0.5 Mb/s, or per SSID below 4 Mb/s.

Wireless only - Enterprise Protocols

- This is a complicated setup, so be sure to reference the [Wireless Connectivity Setup and Verification Procedure for Discover Tablet Consoles](#) for specific details with screen shots for the various Wireless Connectivity setups. The document is posted on [LFTechSupport.com](#).
- **General information:**
 - *Life Fitness* supported types of Enterprise Protocols:
 - EAP-PEAP
 - EAP-TLS
 - EAP-TTLS
 - Gather information from the Facility (IT person) on the setup of the Enterprise Protocol network.

- If more information is required, gather as much information as possible from the customer and contact *Life Fitness* Customer Support.

7. Software

Choose Your Workout

Scroll the **Choose Workout** screen to view available workout options.

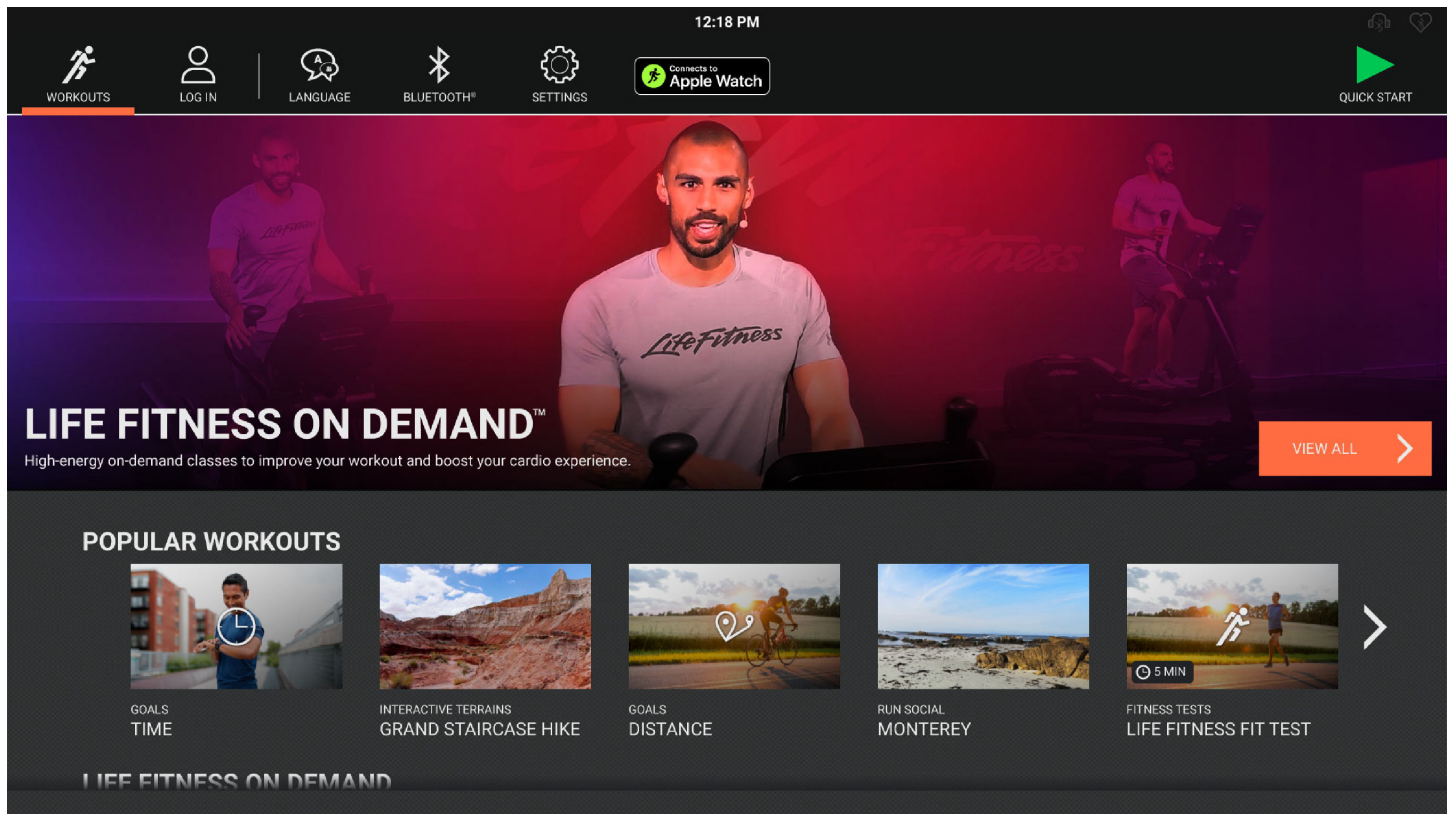

Workouts include:

- **Life Fitness on Demand™** - Select an instructor-led class streamed through the internet.
- **Popular Workouts** - Select a workout that is frequently chosen by exercisers.
- **Interactive Terrains** - Select an interactive terrain and work out with friends or other exercisers anywhere in the world in real time.
- **Standard Goals** - Choose a workout based on desired goal.
- **Fitness Tests** - Select from available fitness tests.
- **Quick Start** - Begin a workout immediately without setup or selecting a goal.

Press on desired workout to access a description about the selected workout.

Press **Start Workout** to access workout setup.

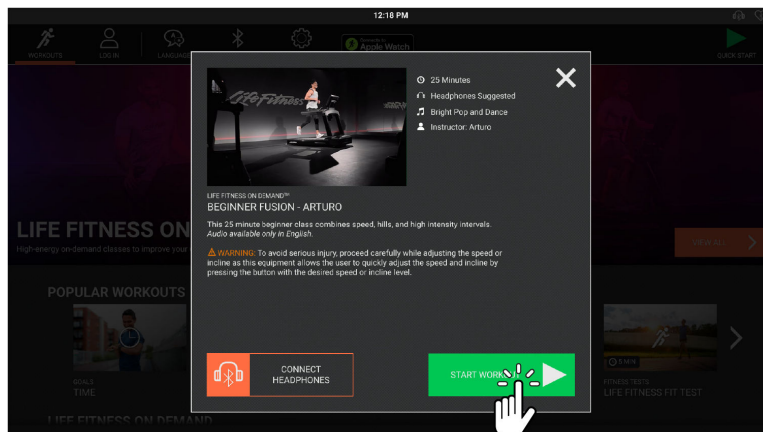

Life Fitness On Demand™

Life Fitness On Demand offers motivational, instructor-led classes ranging in length from 10 to 40 minutes, available on Life Fitness treadmills, cross-trainers, Arc Trainers, PowerMills, upright bikes, and recumbent bikes. The classes are designed for a wide range of exercisers, from beginner to advanced. The classes are streamed through the internet. Software updates are not required in order to view new classes.

Internet Bandwidth Requirements

Life Fitness On Demand requires a strong internet connection for optimal user experience. **At least 2.5 Mbps per machine is recommended.**

Internet bandwidth, otherwise known as your network connection speed, is measured in Megabits per second (Mbps). To find out what your facility bandwidth is, we recommend free online websites like [speedtest.net](https://www.speedtest.net) or [fast.com](https://www.fast.com). Simply open one of these websites on a device with a browser that is connected to your wired internet or WiFi network. The website will show you a measure of your connection speed in Mbps, then compare it to the table below.

Minimum Download Bandwidth Requirements

Services	Up to 8 Units	Each Additional Unit
Asset management, remote software updates, and user workout tracking	2.5 Mbps	0.25 Mbps
Above services and web browsing access	4 Mbps	0.25 Mbps
Above services and web video, e.g. YouTube	4 Mbps	0.5 Mbps
Above services and video streaming apps, e.g. Netflix	8 Mbps	1.0 Mbps
Above services and Life Fitness On Demand classes	20 Mbps	2.5 Mbps

If your facility has low bandwidth we recommend that you enable Life Fitness On Demand only on a select number of units. You may experience lagging internet connectivity if you do not have the appropriate bandwidth. Use this chart as a guide:

Bandwidth in Mbps	Recommended Number of Units Enabled
20	8
40	16
60	24
80	32
100	40

NOTE: Life Fitness On Demand can be enabled through [Halo.Fitness](#) or [Accessing System Options](#).

Life Fitness On Demand™ Video Library

The following conditions must be met for the video library to appear:

- Life Fitness On Demand must be enabled on the unit. Life Fitness On Demand can be enabled on [Halo.Fitness](#) or in [Accessing System Options](#).
- The unit must be connected to the internet.
- The unit must be updated with software version 4.10 or later.

Selecting and Using a Video

1. Select **View All** to view complete Life Fitness On Demand library or select videos listed under Popular Workouts. Scroll down to view Life Fitness On Demand category.

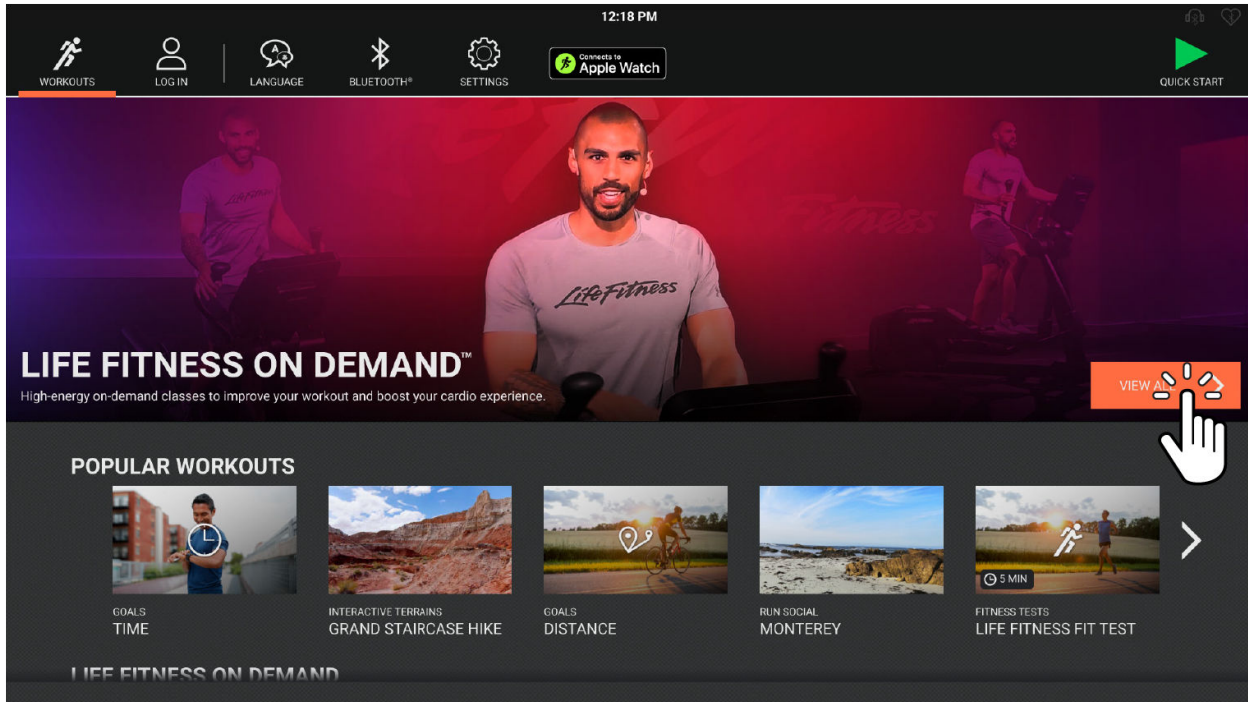

2. Tap on a Life Fitness On Demand workout tile to display more details about the selected class. Exercisers can pair their Bluetooth headphones by tapping **Connect Headphones** and following the prompts.

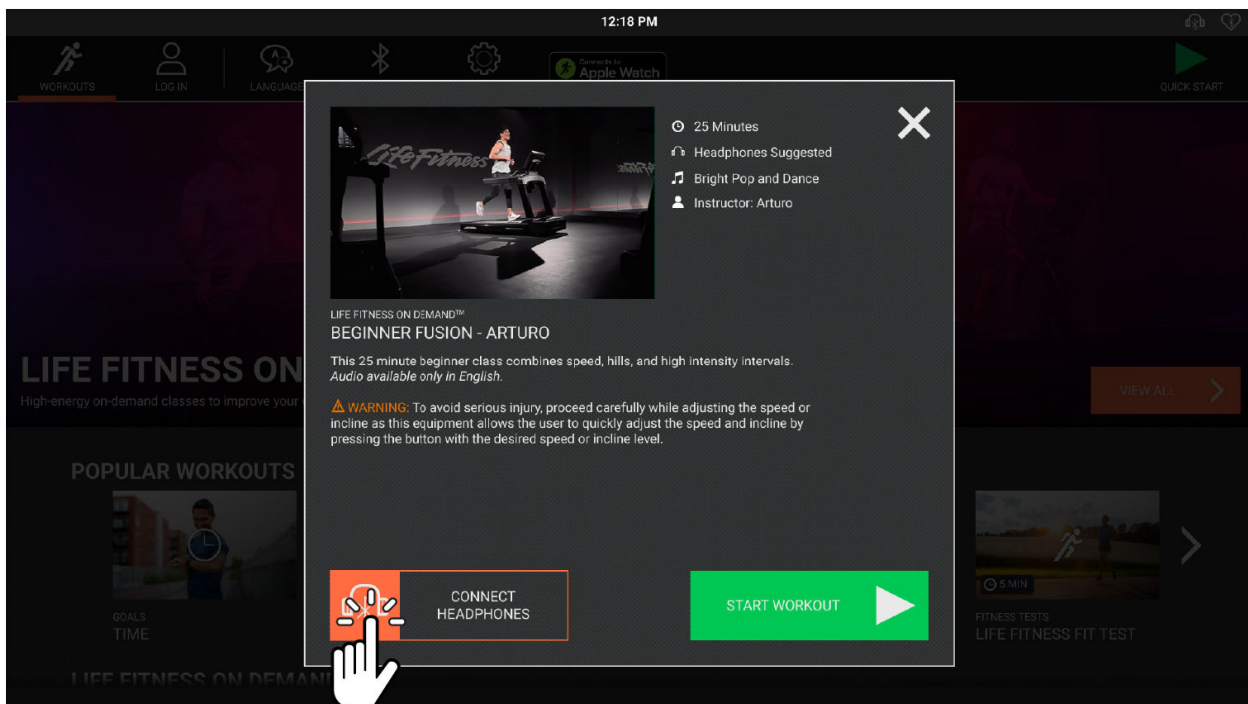

3. Use the quick-touch buttons to adjust workout settings such as speed, incline and resistance.

NOTE: Quick-touch buttons vary depending on workout. Image shown is a treadmill workout.

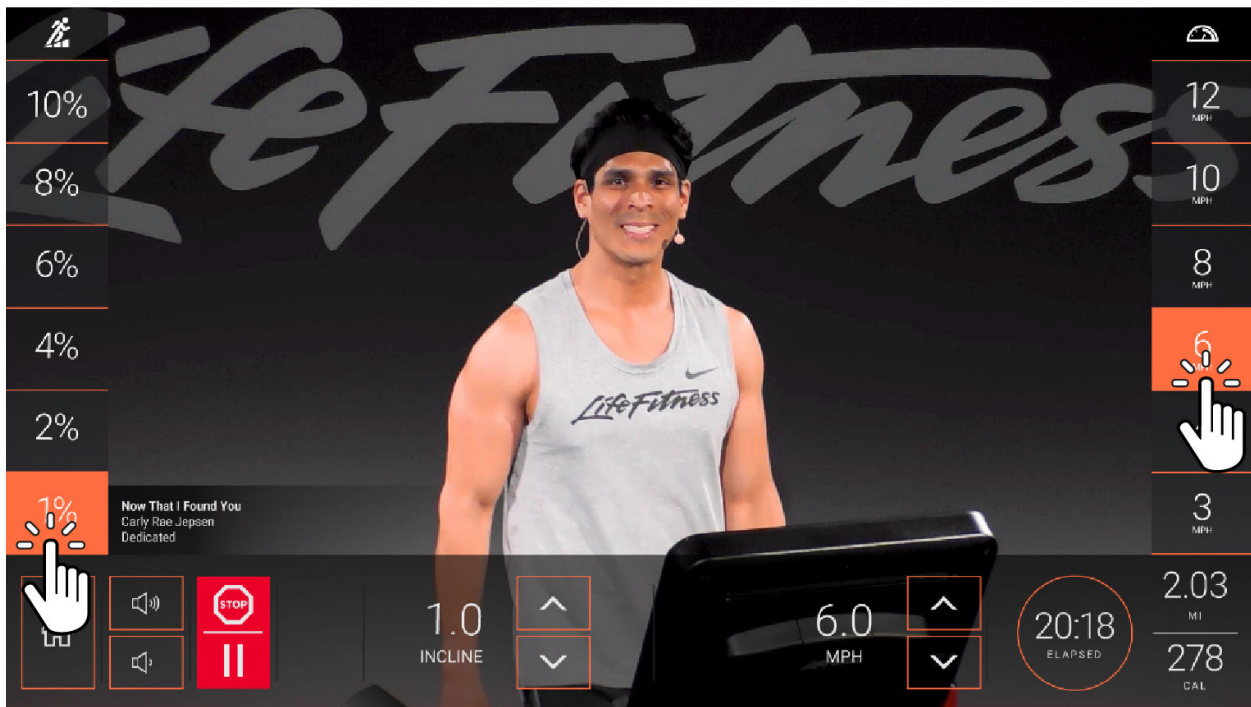

Update Console Software

If Console is not connected to Halo, download the Console software zip file from [Halo Fitness Cloud](#) and store file in the top level directory on any Windows formatted FAT32 USB stick. See the following article for instructions on [How to Download Console Software from Halo Fitness Cloud](#).

1. Press **Go to Workouts** quick jump button 1x (located in right hand column next to main graphic).

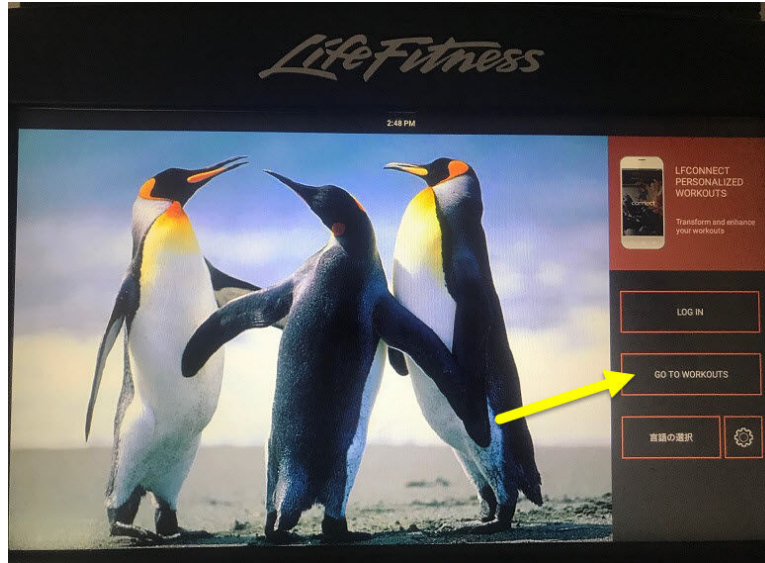

2. The Workout selection screen will appear. Touch the top corners of the touchscreen in the following sequence: **LEFT, RIGHT, LEFT, and RIGHT**.

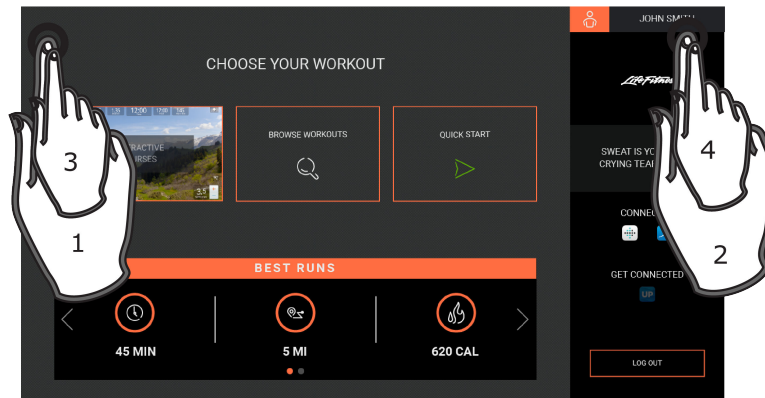

3. Press **Software Updates** under **System Options**, then **Update**.

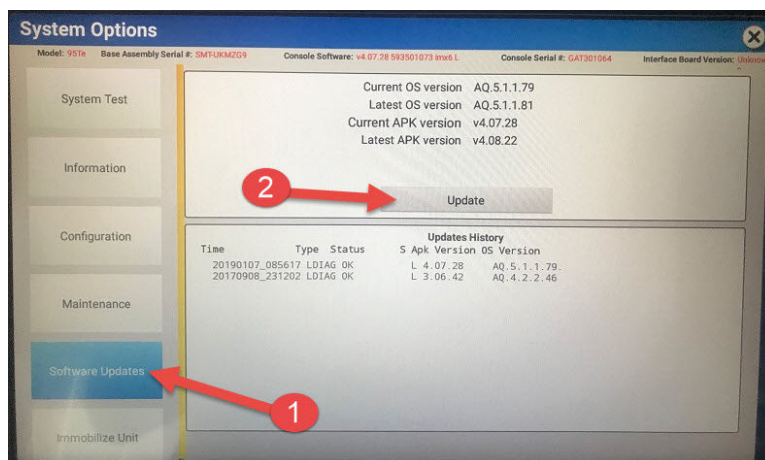

4. OS image will be updated:

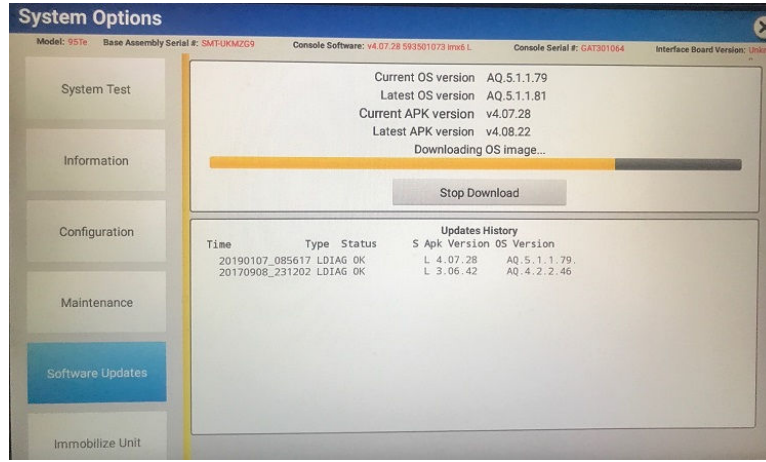

5. APK's will be downloaded:

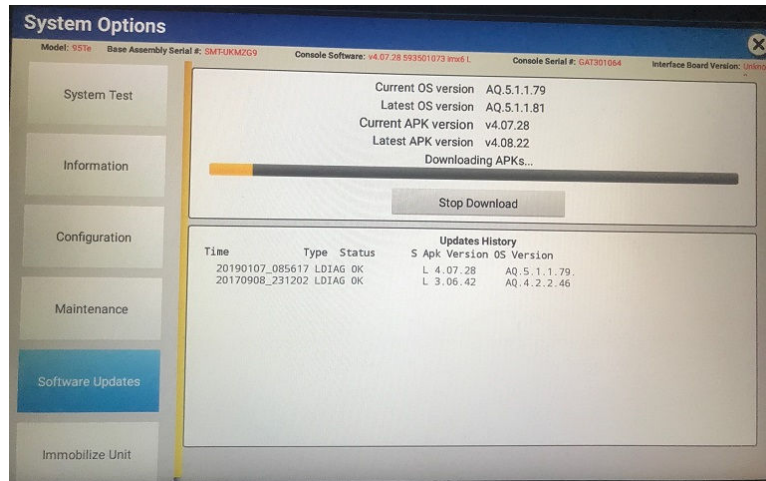

6. Close System Options Dialog by selecting the X in the upper right corner:

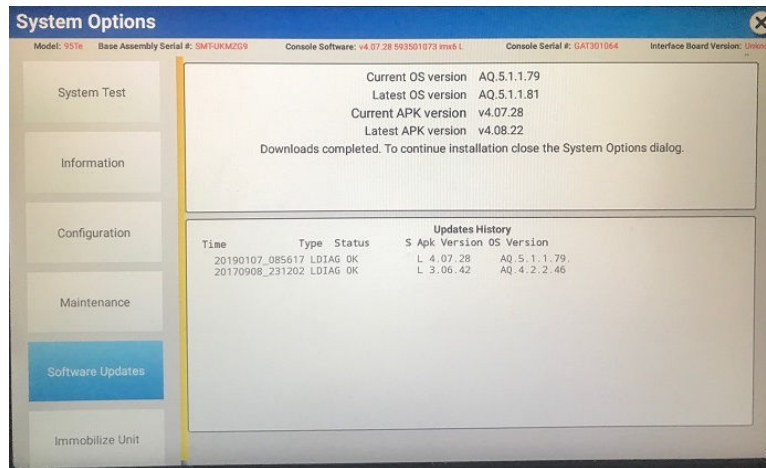

7. Installation progress continues copying data in setup utility screen:

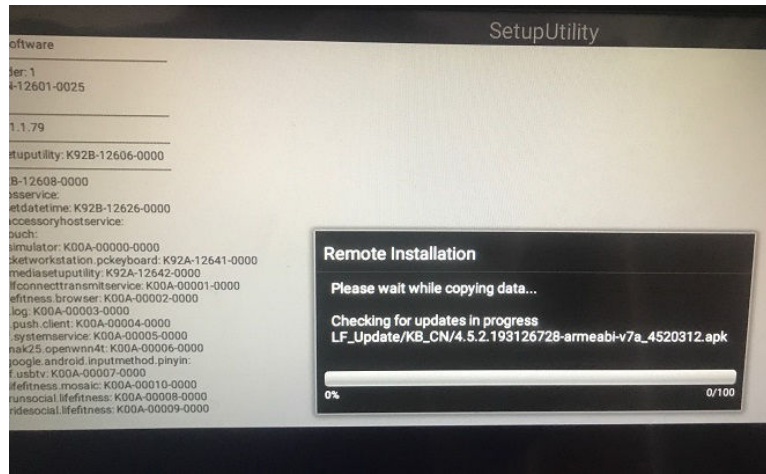

8. 3rd Party Apps are installed:

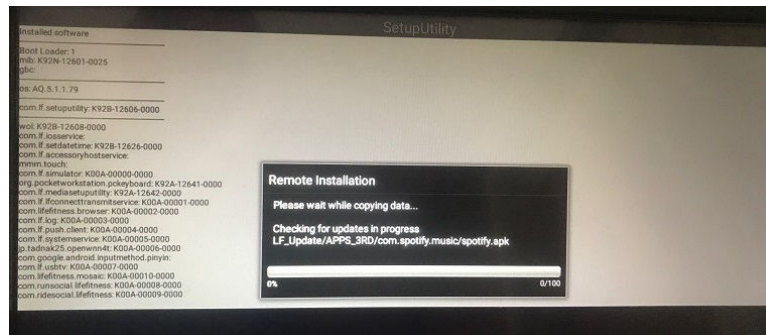

9. Installing System Update robot screen is shown

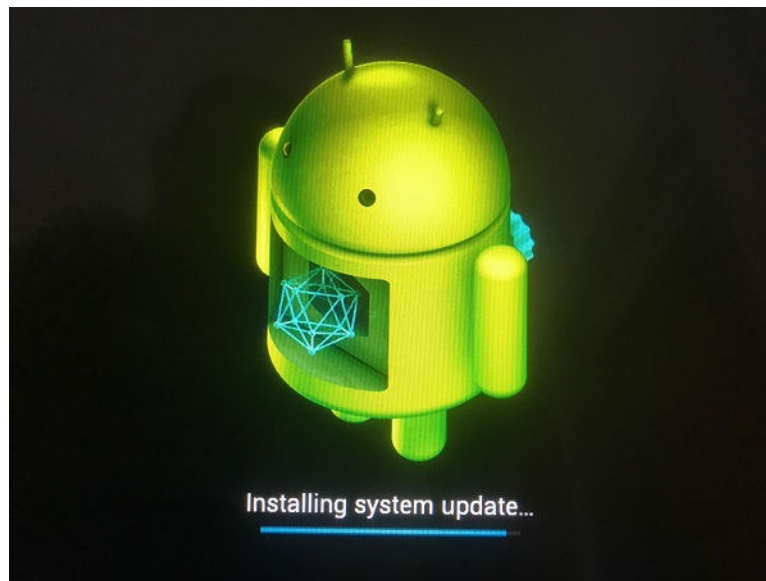

10. System update continues to progress with Running Man screen



11. Applications are then installed.

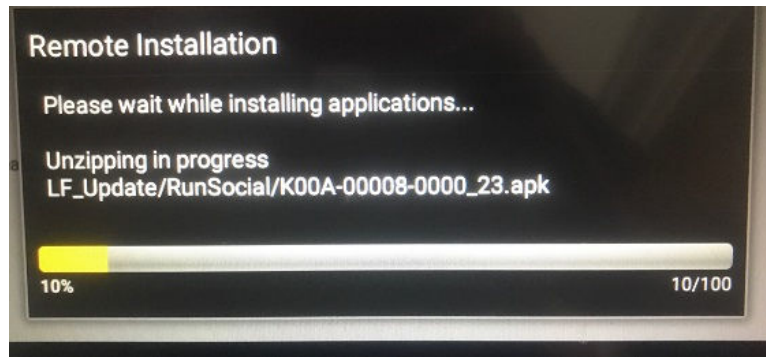

12. 3rd Party applications will be installed next:

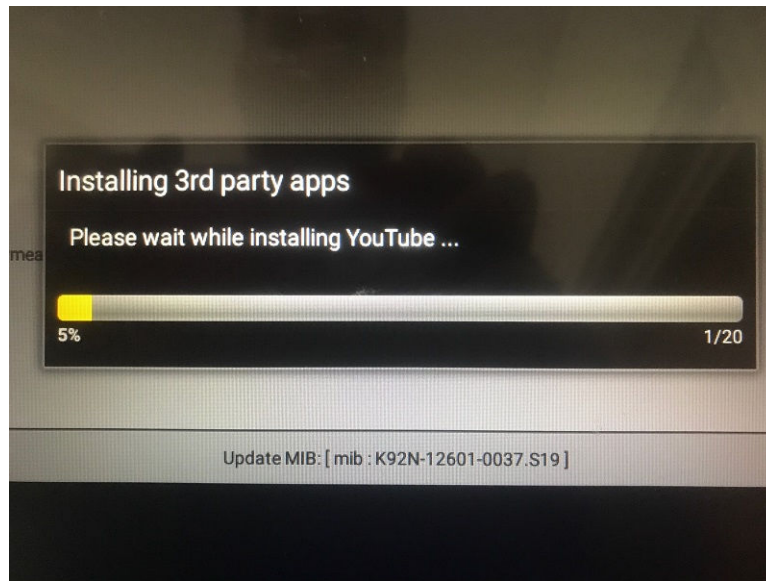

13. Finally MIB is programmed which then completes the software update.

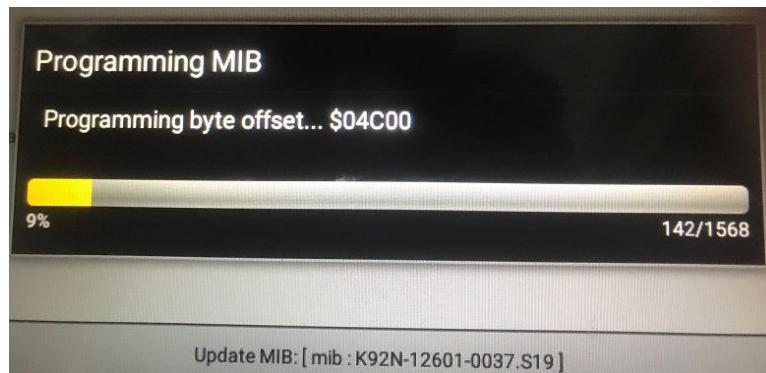

14. Verify software version by selecting the **Go To Workouts** button. Touch the top corners of the touchscreen in the following sequence: **LEFT**, **RIGHT**, **LEFT**, and **RIGHT**. Once in System Options, select **Information** > **Software Versions**:

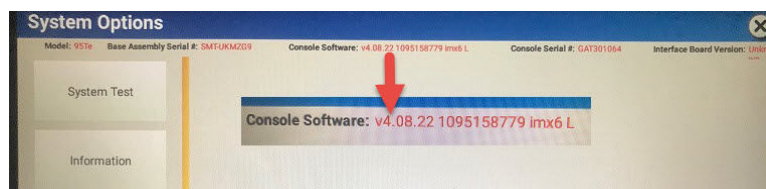

How to perform a System Recovery for the Console

If a console is deemed completely non-responsive or if the Image on the console is upside down, a System Recovery can be attempted to recover proper console functionality. If the System Recover method is not successful, then the console will need to be replaced.

NOTE: This procedure will only cover consoles with IMX6 COM boards. If your console has an IMX53 COM board, then please contact Life Fitness Customer Service for assistance, or order a replacement console.

There are two methods to perform a System Recovery of the console:

- **USB Method of System Recovery (IMX6 COM)** This can be used if the console System Options can be accessed.
- **SD Card method of System Recovery (IMX6 COM)** This will need to be used if you cannot access the System Options of the console. If the Image is upside down or if the console is frozen, this method can be used.

USB Method of System Recovery (IMX6 COM)

1. Obtain the OS image ZIP file `PCI_MX6_SL.ZIP`. This image zip file is provided with every upgrade package.
2. Using a PC, unzip the `PCI_MX6_SL.ZIP` file to a folder. You will have a file like this (this filename might be slightly different depending on the release): `SU.5.1.1.XX.PND`
3. Place the unzipped file in the root directory of a clean USB drive.
4. Power-up the console.
5. Enter System Options and then Manufacturer's configuration.

NOTE: To enter Manufacturer's configuration, swipe a finger back and forth within the System Options title bar until a numeric keypad is displayed. Then enter **919** and **Check mark**.



6. Press the **Exit Application** button to get to the Android desktop.
7. Insert the USB stick with PND image.
8. Press the button that looks like a "3x2 grid" at the bottom of the screen.
9. Press the icon named **System Update** icon to start the update process.
10. Select the **udisk** folder (at the top of the screen) and you will see the **SU.5.1.1.XX.PND** file from step 2.
11. Press this **SU.5.1.1.XX.PND** file, and the console will begin downloading files from the USB stick.
12. The console software will then do a soft reboot and display `Installing system update...`
13. The console will reboot after the software update is complete.
14. Remove the USB stick.
15. Using a PC, copy the latest software onto the USB stick.
16. Insert the USB stick containing the latest software and wait a few minutes. The system will check and upgrade (if necessary) the secondary software components like the MIB, GBC, etc.
17. The console System Recovery process is complete.

SD Card Method of System Recovery (IMX6 COM)

1. Obtain the OS image ZIP file `PCI_MX6_SL.ZIP`. This image zip file is provided with every upgrade package.
2. Using a PC, unzip the `PCI_MX6_SL.ZIP` file to a folder. You will have a file like this (this filename might be slightly different depending on the release): `SU.5.1.1.XX.PND`
3. Place the unzipped file in the root directory of a clean SD Card.
4. Rename the extension of the file to lowercase letters `.pnd`
5. Power down the console.
6. Insert the SD card into the SD card slot on Carrier board at the back of the console.

NOTE: If an SD card is already installed, remove for now and save it for re installation after System Recovery.

7. Power-up the console, and wait.
8. The console will start the recovery process (like a terminal appearance) automatically.
9. The console will then reboot after the update is complete.

- 10.** Remove the SD card. Reinstall the original SD card if there was one removed in step 6.
- 11.** Using a PC, copy the latest software onto the USB stick.
- 12.** Insert the USB stick containing the latest software and wait a few minutes. The system will check and upgrade (if necessary) the secondary software components like the MIB, GBC, etc.
- 13.** The console System Recovery process is complete.

8. Diagnostics

Diagnostic menus display service information.

Accessing System Options

A software update created a new method to access the system options. Use one of the following procedures for your console:

- [Accessing System Options - Prior to software version 4.8.46](#)
- [Accessing System Options - After software version 4.09](#)

Accessing System Options - Prior to software version 4.8.46

1. Go to the **Choose Your Workout** screen.
2. Touch the top corners of the touchscreen in the following sequence: **Upper-Left, Upper-Right, Upper-Left, Upper-Right**.

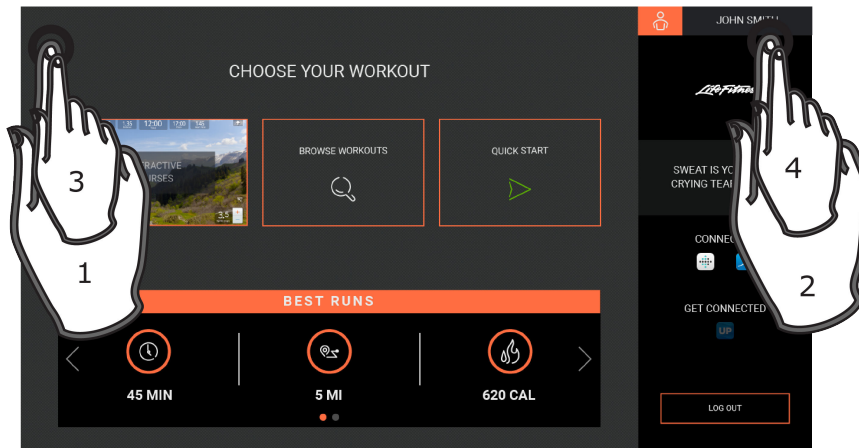

3. System Options menu:

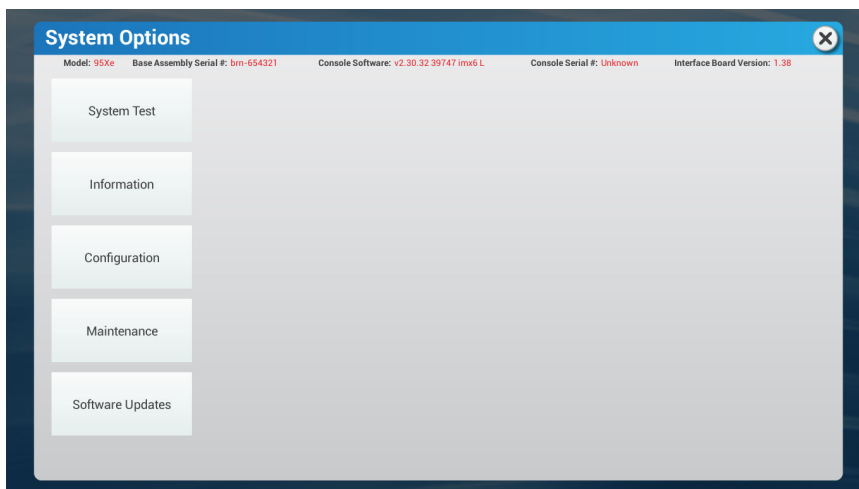

Accessing System Options - After software version 4.09

1. Select **Language** icon from Attract Screen to access the **Select Language** screen.



2. Tap the bottom part of the **Select Language** screen in the following sequence: **Lower-Left, Lower-Right, Lower-Left, Lower-Right**.

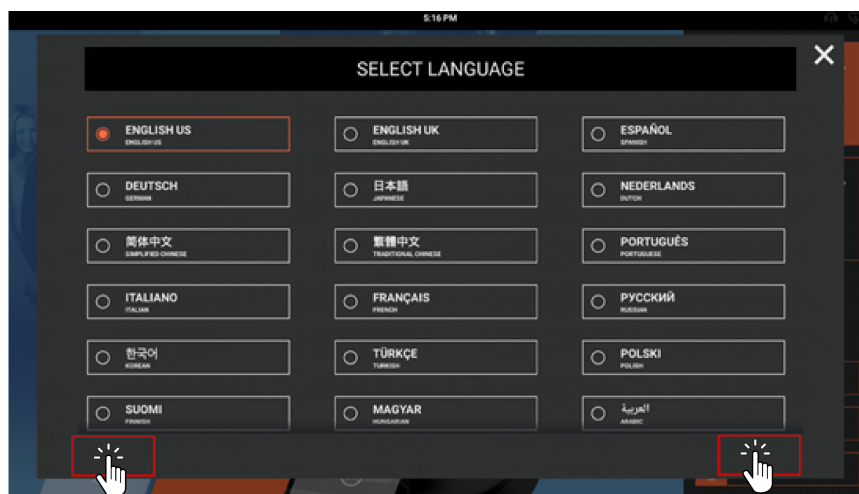

3. Navigate through the System Options menu.

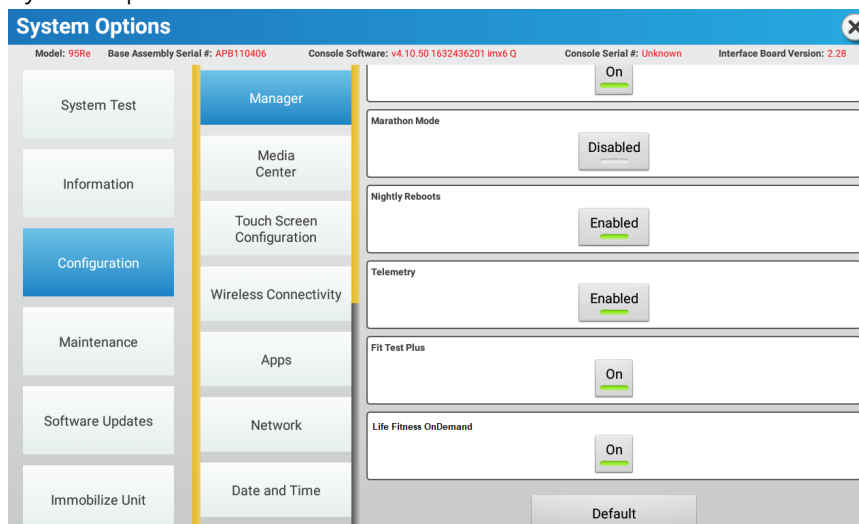

Manager - Default Settings

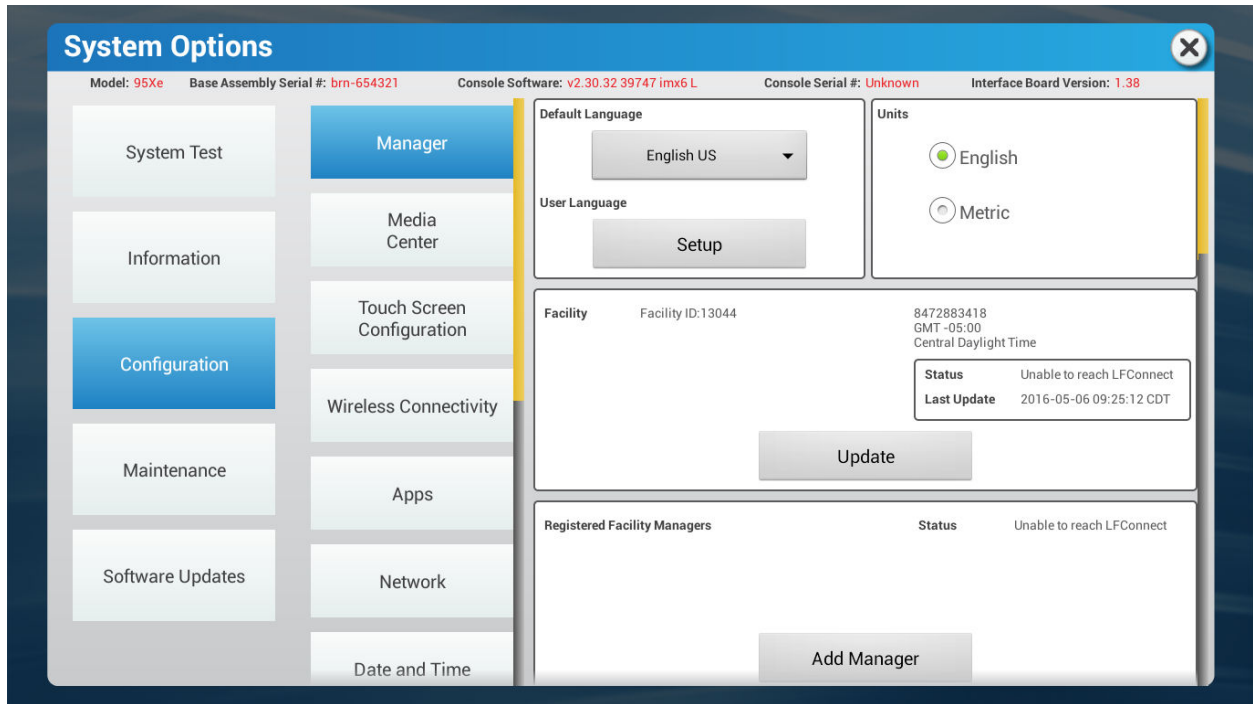

Discover SE3HD Cardio Products

Setting	Default	Description
Default Language	English US	This option sets a new default language. Choices include: <i>English, Spanish, and French.</i>
User Language	English US	This option sets the language of user messages and service messages. Choices include: <i>English, Japanese, Italian, Turkish, Arabic, English UK, Dutch, French, Polish, Catalan, Simplified Chinese, Traditional Chinese, Spanish, Russian, Finnish, Basque, German, Portuguese, Korean, Hungarian, Hebrew and Welsh.</i>
Units	English	Set the measurement unit type for weight, distance, height, and speed. NOTE: Metric available.
Facility	On	This option creates facility information.
Registered Facility Manager	On	This option creates facility management information.
Workout Duration Configuration	60 minute max	Set maximum workout duration limits. 99 minutes maximum.
Pause Time	1 minute	Set the maximum time during which a workout can remain in pause mode. 99 minutes maximum.
Program Timeout	30 seconds	The amount of time, ranging from 0 - 255 seconds, a user can go without touching the LCD touch screen during workout setup before the unit returns to the Home Screen.
InActivity Timer	On, 2 hours	Set the desired amount of time of inactivity before the system automatically turns off the LCD touch screen backlight.
Auto Off / Auto On	Off	Set the time of day for the system to automatically turn off the LCD touch screen backlight.

Setting	Default	Description
System Sounds	On	This option controls whether the system speaker beep is generated on key presses.
Marathon Mode	Enabled	This option allows the user to workout indefinitely.
Life Fitness On Demand	Off	This option activates complete access to the growing library of Life Fitness instructor-led classes. NOTE: The library will only appear if the unit is connected to the internet. 2.5 Mbps of bandwidth per unit recommended for optimal functioning.
Nightly Reboots	Off	When turned on, the console will detect the least active time of day for the unit and automatically reboot every 24 hours at that time. This is recommended for optimal functioning of streaming services, like Life Fitness On Demand or Netflix.
Telemetry	Enabled	Switching on the telemetry feature makes it possible to use the Polar®-compatible Heart Rate Zone Training exercises with a Polar telemetry heart rate chest strap for monitoring the heart rate.
Speed Increase Limiting with Up Key	Off	When enabled, the user cannot press and hold the speed button to increase the speed.
Fit Test Plus	On	Turns on/off the US Navy test and FAMS

Treadmill Only

Setting	Default	Description
Maximum Speed	14.0 MPH (23 KPH)	Set the fastest speed the treadmill can operate.
Minimum Speed	0.5 MPH (0.8 KPH)	Set the slowest speed the treadmill can operate.
Maximum % Incline	15.0	This option changes the maximum incline grade to a value lower than 15%.
Activity Zone Speed Keys	Enabled	This option allows the user to assign belt speed to Walk / Jog / Run values.
Stride Sensor (95T only)	On	This option automatically pauses the workout if the user steps off the belt.
Deceleration Rate	3	The rate at which the treadmill decelerates to the selected speed, ranging from 1 (slowest) to 5 (fastest).
Acceleration Rate	3	The rate at which the treadmill accelerates to the selected speed, ranging from 1 (slowest) to 5 (fastest).
Turn OFF Stride Sensor Notification	Stride Sensor Button On Pause Button Disabled	This option detects a user using a treadmill but will not go into Pause mode if a user is not detected.

PowerMill Only

Setting	Default	Description
Warm Up Speed: Level 0 (12-19 SPM)	Off	This option, if enabled, controls whether or not Level 0 may be used in program setup or during a workout. Level 0 corresponds to intensity levels below Level 1.
High Speeds: Level 21-25 (160-182 SPM)	On	This option controls whether or not Levels 21 through 25 may be used in program setup or during a workout (MANUAL and SPEED INTERVAL workouts ONLY).

Setting	Default	Description
Calorie Per Hour (CPH) Display	On (International: Off)	If this option is enabled, the MESSAGE CENTER displays the number of calories burned per hour during the workout.
Steps Climbed Display	Off	If this setting is enabled, the total number of steps climbed is periodically shown during a workout.
Max Acceleration Rate	3	This sets the rate at which the PowerMill Climber accelerates to the selected speed, ranging from one (slowest) to five (fastest).
Max Deceleration Rate	3	This sets the rate at which the PowerMill Climber decelerates to the selected speed, ranging from one (slowest) to five (fastest).
Minimum Speed (SPM)	20 SPM	Set the slowest speed the PowerMill can operate.
Maximum Speed (SPM)	160 SPM	Set the fastest speed the PowerMill can operate.

9. Error code list

Error codes notify user of a problem condition and are displayed on the console. Error codes can also help to indicate the part of the unit most likely to be causing the problem.

- [Error 20](#)
- [Error 21](#)
- [Error 25](#)
- [Error 26](#)
- [Error 27](#)
- [Error 31](#)
- [Error 33](#)
- [Error 34](#)
- [Error 38](#)
- [Error 39](#)
- [Error 47](#)
- [Error 49](#)
- [Error 60](#)
- [Error 61](#)
- [Error 62](#)
- [Error 63](#)
- [Error 64](#)
- [Error 66](#)
- [Error 70](#)
- [Error 71](#)
- [Error 72](#)
- [Error 73](#)
- [Error 74](#)
- [Error 75](#)
- [Error 76](#)
- [Error 77](#)
- [Error 78](#)
- [Error 79](#)
- [Error 80](#)
- [Error 81](#)
- [Error 82](#)
- [Error 83](#)
- [Error 84](#)
- [Error 89](#)
- [Error 90](#)
- [Error 91](#)
- [Error 93](#)
- [Error 94](#)
- [Error 101](#)
- [Error 110](#)
- [Error 120](#)
- [Error 121](#)
- [Error 122](#)
- [Error 123](#)
- [Error 124](#)
- [Error 125](#)
- [Error 126](#)
- [Error 127](#)
- [Error 128](#)
- [Error 129](#)
- [Error 131](#)
- [Error 132](#)
- [Error 135](#)
- [Error 136](#)
- [Error 137](#)
- [Error 138](#)
- [Error 141](#)
- [Error 142](#)
- [Error 143](#)
- [Error 148](#)
- [Error 149](#)
- [Error 151](#)
- [Error 152](#)
- [Error 153](#)
- [Error 155](#)
- [Error 157](#)
- [Error 601](#)
- [Error 602](#)

Error 20

Error Message Displayed to user

- E20
- Notify Maintenance!
Module Comm Error!

Condition

Console not communicating with the motor controller (base), at power-up.

Cause

- Un-programmed base board or installed console software does not support the product type/base.
- Bad, loose or pinched cables
- Improperly seated connectors
- Bad Motor Controller/base PCB
- Bad Console PCB/MIB
- Bad Keypad controller (Integrity PowerMill)

Remedy

- Ensure the SIB-MDB cable part 1004243-000 is plugged securely in to the PC Board assembly to resolve this error.

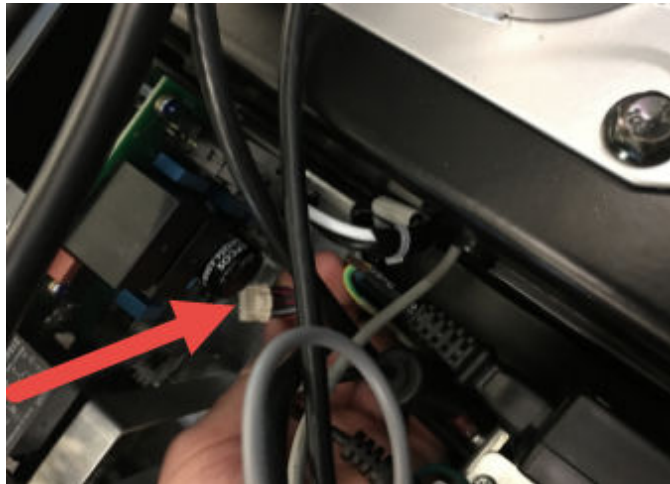

- Ensure that latest software is installed. Download the latest software <https://www.halo.fitness/web/softwareDownload.html>.
- Check com cable between console and base for damage
- Unseat and reseat com cable connections, wiggle cables - watch for LED flickers that may indicate loose connections
- Ensure the following LED's are lit: SIB (1,2,4,5, 14, & 16), MDB (100, 101, 200, 400, 500, 501, 502, 601) (KB 2843)
- Check console boards for power, are LED's lit?
- Check keypad controller connection
- Replace unfit boards or cabling

Error 21

Error Message Displayed to user

- E21
- Notify Maintenance!
Communication Timeout
(Motor Controller)
- Notify Maintenance!
Communication Timeout
(Incline Controller)

Condition

Lost Communication with a Controller, after initially communicating.

Cause

- Bad Cables
- Bad Motor Controller
- Bad Console [PCB/MIB](#)

Remedy

- Ensure that latest software is installed. Download the latest software <https://www.halo.fitness/web/softwareDownload.html>.
- Check com cable between console and base for damage
- Unseat and reseat com cable connections, wiggle cables - watch for [LED](#) flickers that may indicate loose connections
- Ensure the following [LED](#)'s are lit: [SIB](#) (1,2,4,5, 14, & 16), [MDB](#) (100, 101, 200, 400, 500, 501, 502, 601)
- Check console boards for power, are [LED](#)'s lit?
- Check keypad controller connection
- Replace unfit boards or cabling

Error 25

Error Message Displayed to user

- E25
- Incline Inoperative
- Incline Inoperative - Continue if desired!

Condition

Lift Home Switch Error. Home switch on Treadmill is not being properly detected/depressed when the system is seeking the home position (0% incline). ARC and Bike LCB error: Incline Movement Feedback Stopped.

Cause

- Bad Home switch
- Bad or loose cable from MC to home switch
- Bad Motor Controller
- Bad Incline Motor
- Incline Motor is in Thermal Protection Mode

Remedy

- Is SIB LED 7 illuminated when home switch depressed?
- Does home switch function, check continuity with DMM
- Ensure home switch connector is fully seated on the SIB board. Ensure cable is secured to home switch.
- If lift motor was being used heavily, wait ten minutes and start another workout. Issue may self resolve.

Error 26

Error Message Displayed to user

- E26
- Incline Inoperative
- Incline Inoperative - Continue if desired!

Condition

Decline switch is not being properly detected / depressed when the system is seeking the maximum decline position (i.e. -3%)

Cause

- Bad decline switch
- Bad cable
- Bad Motor Controller
- Bad Incline Motor
- Incline Motor is in Thermal Protection Mode

Remedy

- Is SIB LED 19 illuminated when decline switch depressed?
- Does home switch function, check continuity with DMM
- Ensure switch connector is fully seated on the SIB board. Ensure cable is secured on switch.
- If lift motor was being used heavily, wait ten minutes and start another workout. Issue may self resolve.

Error 27

Error Message Displayed to user

- E27
- Incline Inoperative
- Incline Inoperative - Continue if desired!

Condition

Lift timeout error.

Cause

- Bad cable
- Bad Motor Controller
- Bad Incline Motor
- Incline Motor is in Thermal Protection Mode

Remedy

- If lift motor was being used heavily, wait ten minutes and start another workout. Issue may self resolve.

Error 31

Error Message Displayed to user

- E31
- Unable to Attain Target Speed! Message goes away after 30 seconds

Condition

Running belt did not reach the target speed within the allotted time.

Cause

- Multiple, frequent speed changes - in older software, the speed attainment timer starts with first speed change request and does not reset for subsequent speed change requests before the timer expires, therefore the equipment may be in the midst of a speed change when the timer expires, this can result in an E31
- Cybex R-Series tread with waxless deck
- Excessive mechanical drag - belt/deck/roller wear or contamination, bearing damage, debris entrapment, etc. can result in speed performance degradation
- Extreme use - combination of high speed and/or high user weight could result in this error

Remedy

- Ensure that latest software is installed. Download the latest software <https://www.halo.fitness/web/softwareDownload.html>.
- For Cybex R-Series treadmills with waxless deck built before 10/3/2018, install waxed deck part number 10055463-0002
- Inspect equipment for excessive drag, check belt and deck, steps, brake, motor and roller bearings, debris entrapment (on, in or under equipment), etc.
- Interview staff - Determine use conditions at time of error, are or was there:
 - Multiple equipment operating on single circuit
 - Low line voltage (brownout)
 - Extreme use: heavy user and/or high speed
 - Extreme use: target speed exceeds user capability
 - Extenuating circumstances that would cause high current draw

NOTE: above average current draw can result in E31 so consider any conditions that could raise current draw, cause could be related to use or environment.

Error 33

Error Message Displayed to user

- E33
- Notify Maintenance Motor Controller Error (Thermal Shutdown) Keep error on screen until **OK** button pressed.

Condition

Error sent by Motor Controller if there is a Motor Controller thermal trip. Temperature sensor on Motor Controller board. Operation suspended.

Cause

- Restricted airflow around Treadmill
- Hot environment
- Bad Motor Controller
- Heavy use
- For Treadmills this indicates overheated Motor Drive Board or Motor
- For PowerMills this indicates overheated motor (E78 indicates overheated MDB)

Remedy

- Clean around equipment, ensure all vents are debris free, vacuum under hood cover if dirty
- If the equipment in a extremely hot environment, cool environment
- Check motor controller LED's
- Was equipment under heavy or high speed use at time of error?
 - This message is sent by the motor controller if it detects a motor controller thermal/temperature trip.
 - Indicates temperature sensor on motor controller board detected high ambient temperature - operations suspended.
 - Can be due to restricted airflow or an excessively hot environment.
 - Clean around machine, make sure it is not near a heat source
 - On treadmills, if **max temp** in main motor info is not over 100, then error due to motor thermal switch
- Replace Motor Drive Board
- Replace motor

Error 34

Error Message Displayed to user

- E34
- Notify Maintenance!
Motor Controller Error
(Hardware Current Trip)

Keep error on screen until **OK** button pressed. End workout.

Condition

Error sent by Motor Controller when it detects an over current condition (i.e. current limit threshold exceeded. Also called - "Controller Fault 1 Trip". Applies to motorized equipment only.

Cause

- Issue with encoder on Power mills (run encoder test to validate).
- Excessive user weight/load
- Bad motor controller
- Bad motor
- Shorted motor cable
- Power module
- Debris entrapment

Remedy

- Run encoder test
- Intermittent connections between motor and motor controller board can cause hardware current trips. This trip is fast acting and an intermittent cable / connector / poor terminal crimp can cause large changes in current draw
- Check motor power cable and connector terminals for damage, unseat and re-seat motor connection to control board
- Check motor phase resistance and ensure isolation between phases and case

Error 38

Error Message Displayed to user

- E38
- Warning - Step Off Belt, Maximum Voltage Trip Keep error on screen until **OK** button pressed. End workout.

Condition

Error sent by the Motor Controller when it detects an over voltage condition. Applies to motorized equipment only.

Cause

- Excessive high speed load on machine
- PowerMills only - Faulty / intermittent bus dump circuit/resistor
- User pushing walking belt
- High incline workout
- High VAC input

Remedy

- For machines with bus dump circuit/resistor, (e.g. PowerMill and some high performance treadmills) the resistor, resistor wiring or Motor Drive Board dump circuit could be faulty
- High line voltage could cause this fault
- Excessive workout: high incline, heavy user, pushing walking belt or steps, or anything that forces motor to go faster than commanded
- This message is sent by the motor controller when it detects an over voltage condition. Can be due to excessive high speed load on the machine or a faulty / intermittent bus dump circuit / resistor (on PowerMills). Verify the power circuitry, advise user of maximum machine limits.

Error 39

Error Message Displayed to user

- E39
- Notify Maintenance No Encoder Error Keep error on screen until **OK** button pressed. End workout.
- Speed Sensor Errors

Condition

Error sent by Motor Controller when the encoder movement is expected but is not being detected. Run encoder test.

Cause

- Bad cables
- Bad or mis-adjusted encoder

Remedy

- Check encoder cable / connection to System Interface Board / PMC board
- Run encoder test
- Replace encoder
- This error will trip when encoder movement is expected but is not being detected by the motor controller. Encoder mis-adjusted or damaged, cable damaged or intermittent connection. Verify cable integrity, run encoder test, replace encoder

Error 47

Error Message Displayed to user

- E47
- Start Up Error

Condition

Message sent by the motor controller when no current is detected while trying to run the belt motor.

Cause

- Bad cables
- Bad motor controller
- Bad motor

Remedy

- Check motor wiring/terminals
- Measure motor thermal switch connections to ensure switch is closed
- Measure motor phase resistance to ensure no open circuits
- Check MDB LED's to ensure properly powered and communicating - replace Motor Controller if faulty (100, 101, 200, 400, 500, 501, 502)
- Diagnose / replace MDB

Error 49

Error Message Displayed to user

- E49
- Notify Maintenance!
Motor Controller Error
(Low Voltage Detected)

Condition

Error sent by motor controller when it detects an under voltage condition (Low Bus Voltage)

Cause

- Low AC voltage / Brownout
- Bad power cord / cables
- Bad MDB

Remedy

Is error repeatable?

Is input voltage = rated +/- 15%?

- Check condition of all AC wiring and terminals (power cord, inlet, power switch, line filter, and / or motor controller connection) - ensure faston connectors have tight fit on tab
- Check MDB LED's to ensure properly powered and communicating - replace Motor Controller if faulty (100, 101, 200, 400, 500, 501, 502)
- Diagnose / replace MDB

Error 60

Error Message Displayed to user

- E60
- Interface Board Not Detected!
- System Comm Init Timeout! Interface Board Not Detected!

Pressing **Cancel** button will initiate a system reboot.

Condition

SBC never established communication with the Maintenance Interface Board.

Cause

- Check connections between main board and Maintenance Interface Board
- Bad Maintenance Interface Board
- Bad SBC / SOM board

Remedy

NOTE: Only applicable to consoles with Maintenance Interface Board

- Reseat cable connections between main board and Maintenance Interface Board, wiggle cables - watch for LED flickers that may indicate loose connections

Error 61

Error Message Displayed to user

- E61
- Interface Board Not Detected!
- System Comm Init Timeout! Interface Board Not Detected! During initialization
- Lost Communication with Interface Board Resetting System..... During workout, 60 second timeout.
- Lost Communication with Interface Board Resetting System..... During idle, 10 second timeout.

Pressing **Cancel** button will initiate a system reboot.

Condition

SBC lost communications with the MIB, after initially communicating successfully.

Cause

- Check connections between main board and Maintenance Interface Board
- Bad Maintenance Interface Board
- Bad SBC / SOM board
- Bad cable(s)

Remedy

NOTE: Only applicable to consoles with Maintenance Interface Board

- Reseat SBC to Maintenance Interface Board cable connectors, wiggle cables - watch for LED flickers that may indicate loose connections
- Replace cables as needed
- Replace console

Error 62

Error Message Displayed to user

- E62

Condition

Error if the motor controller has unexpectedly disabled the main/belt motor.

Cause

- Motor Controller improperly jumpered (on PowerMill)

Remedy

- Check motor controller jumpers
- Check all AC, motor and/or encoder wiring and terminals
- Unseat and reseal all connections

Error 63

Error Message Displayed to user

- E63

Condition

The Interface (Maintenance Interface Board) board software has failed a check sum integrity check. The board needs to be programmed or replaced.

Cause

- Software corrupted
- Reprogram

Remedy

- Reprogram Maintenance Interface Board
- Replace Maintenance Interface Board

Error 64

Error Message Displayed to user

- E64
- Unexpected Interface Board Reset!

Pressing **Cancel** button will initiate a system reboot.

Condition

Occurs when the Interface board goes through a reset but the Single Board Computer did not. Pending workouts are terminated. Single Board Computer reconnects with the interface board to fix.

Cause

- Reset power to console to allow full reset.

Remedy

- Power cycle unit
- Ensure that latest software is installed. Download the latest software <https://www.halo.fitness/web/softwareDownload.html>.
- Replace console

Error 66

Error Message Displayed to user

- E66
- Stop Key Activated!

Condition

One or more hard keys on the Activity Zone or console overlay have been held down or pressed at the same time. Maintenance Interface Board sees this as a stop key press. Test Keypads and cables.

Cause

- One or more keys (Activity Zone or console keypads) are stuck
- Activity Zone cable

Remedy

- Is the error persistent? If yes, check for damaged keys on console or activity zone.
- Recycle the power. If the key remains stuck, the console will display **PLEASE WAIT** until the stuck key error is displayed again.
- Determine the stuck key.
 - Replace the console if the problem is a key on the console.
 - Replace the activity zone membrane keypad or the activity zone circuit board depending on the product if the problem is not in the console.

Determine location of the stuck key:

Along with the stuck key message the console will also display codes that can be used to determine which key or keys are stuck. The key identification information is arranged in a table with six columns and four rows. The console software will continually scan through this table of keys one column at a time. The heart rate window will display the column in the table currently being checked. The calorie window will display a key identification number. The identification number will remain at 0000 unless a key is found to be stuck. Record the column number and any non-zero key identification numbers. Be sure to keep watching the display and recording until the console has checked all six columns. See tables for an example of the error message and key information.

Treadmill

	Column Number					
Key ID	0	1	2	3	4	5
0010	Console Pause	Console Arrow Up	Console Reset	Activity Zone Walk	Activity Zone Run	Activity Zone Mid Incline
0020	Console Enter / Start	Console Arrow Right	Console User Profile*	Activity Zone Speed Down	Activity Zone Start	Activity Zone Incline Up
0040	Console Arrow Left	Console Arrow Down	Console Settings*	Activity Zone Speed Up	Activity Zone Stop	Activity Zone Incline Down
0080	Console Race Mode*	Console Goal Workouts*		Activity Zone Jog	Activity Zone High Incline	Activity Zone Low Incline

* Denotes keys that are only on the Advanced console

Bike and Cross-Trainer

	Column Number					
Key ID	0	1	2	3	4	5
0010	Console Pause	Console Arrow Up	Console Reset	Activity Zone Lower Body	Activity Zone Total Body	Activity Zone Resistance Up
0020	Console Enter / Start	Console Arrow Right	Console User Profile*		Activity Zone Start	

	Column Number					
0040	Console Arrow Left	Console Arrow Down	Console Settings*	Activity Zone Resistance Down	Activity Zone Stop	
0080	Console Race Mode*	Console Goal Workouts*				

* Denotes keys that are only on the Advanced console

Error 70

Error Message Displayed to user

- E70

Condition

Reported by Maintenance Interface Board board when temperature exceeds trip point

Cause

- Clogged console ventilation
- Hot environment
- Console problem

Remedy

- Ensure console adequately ventilated
- If persistent and properly ventilated, Maintenance Interface Board / console may need to be replaced

Error 71

Error Message Displayed to user

- E71
- Stuck hard key detected.

Condition

Reported by Maintenance Interface Board board when one or more keys are held in at power-up.

Cause

- Stuck key on Activity Zone
- Stuck key in console

Remedy

- Is the error persistent? If yes, check for damaged keys on console or activity zone.
- Recycle the power. If the key remains stuck, the console will display **PLEASE WAIT** until the stuck key error is displayed again.
- Determine the stuck key.
 - Replace the console if the problem is a key on the console.
 - Replace the activity zone membrane keypad or the activity zone circuit board depending on the product if the problem is not in the console.

Determine location of the stuck key:

Along with the stuck key message the console will also display codes that can be used to determine which key or keys are stuck. The key identification information is arranged in a table with six columns and four rows. The console software will continually scan through this table of keys one column at a time. The heart rate window will display the column in the table currently being checked. The calorie window will display a key identification number. The identification number will remain at 0000 unless a key is found to be stuck. Record the column number and any non-zero key identification numbers. Be sure to keep watching the display and recording until the console has checked all six columns. See tables for an example of the error message and key information.

Treadmill

	Column Number					
Key ID	0	1	2	3	4	5
0010	Console Pause	Console Arrow Up	Console Reset	Activity Zone Walk	Activity Zone Run	Activity Zone Mid Incline
0020	Console Enter / Start	Console Arrow Right	Console User Profile*	Activity Zone Speed Down	Activity Zone Start	Activity Zone Incline Up
0040	Console Arrow Left	Console Arrow Down	Console Settings*	Activity Zone Speed Up	Activity Zone Stop	Activity Zone Incline Down
0080	Console Race Mode*	Console Goal Workouts*		Activity Zone Jog	Activity Zone High Incline	Activity Zone Low Incline

* Denotes keys that are only on the Advanced console

Bike and Cross-Trainer

	Column Number					
Key ID	0	1	2	3	4	5
0010	Console Pause	Console Arrow Up	Console Reset	Activity Zone Lower Body	Activity Zone Total Body	Activity Zone Resistance Up
0020	Console Enter / Start	Console Arrow Right	Console User Profile*		Activity Zone Start	
0040	Console Arrow Left	Console Arrow Down	Console Settings*	Activity Zone Resistance Down	Activity Zone Stop	

	Column Number					
0080	Console Race Mode*	Console Goal Workouts*				

* Denotes keys that are only on the Advanced console

Error 72

Error Message Displayed to user

- E72
- Activity Zone keypad not detected.

Condition

Reported by Maintenance Interface Board board when Activity Zone keypad is not connected / detected

Cause

- Activity Zone keypad is disconnected
- Damaged cable to Activity Zone
- Damaged Activity Zone

Remedy

- Ensure that latest software is installed. Download the latest software <https://www.halo.fitness/web/softwareDownload.html>.
- Check Maintenance Interface Board to Activity Zone cable condition
- Reseat Maintenance Interface Board to Activity Zone cable connections
- Replace Activity Zone keypad
- Replace Maintenance Interface Board

Error 73

Error Message Displayed to user

- E73
- Activity Zone keypad not detected.

Condition

Indicates a short / over-current condition to the VCardio power pin on the CSAFE port(s).

Cause

- CSAFE connected device or cable shorted
- Bad CSAFE board (Explore)
- Bad board (which contains the CSAFE connector)

Remedy

- Check CSAFE cable for damage, replace
- Replace CSAFE device

Error 74

Error Message Displayed to user

- E74
- Emergency Stop Drive Trip.

Condition

The console's Emergency stop switch (i.e. E-Stop) drive circuitry detected a shorted condition.

Cause

- E-Stop switch components damaged
- Cable to E-Stop circuit pinched
- Explore: Life Pulse / Activity Zone Printed Circuit Board is disconnected or a bad connection
- Explore: Life Pulse / Activity Zone Printed Circuit Board is bad

Remedy

- Ensure E-Stop sensor is in position and secure
- Ensure E-Stop cable is in good condition and not pinched
- Life Pulse and Activity Zone connected, unseat and reseat
- Life Pulse or Activity Zone bad

Error 75

Error Message Displayed to user

- E75
- doStartWorkflow-Up Failure

Condition

System unexpectedly timed out retrieving base data at power-up. Retry to power up first to see if there was a temporary failure. If problem persists, then check other causes.

Cause

- Comm cables from base to console
- Low battery
- Intermittent / low power
- Ensure that latest software is installed. Download the latest software <https://www.halo.fitness/web/softwareDownload.html>.

Remedy

- Cycle power
- Check and reseal console to base cables, wiggle cables - watch for LED flickers that may indicate loose connections
- Check base boards for signs of life. Ensure the following LED's are lit:
 - System Interface Board (1,2,4,5, 14, and 16)
 - Motor Drive Board (100, 101, 200, 400, 500, 501, 502, 601)
 - AC and DSP (1, 2, 6, 7, 8)
 - PMC (1, 2, 6, 7, 8, 11)
- Check battery voltage is above 6V

Error 76

Error Message Displayed to user

- E76
- System Error

Condition

Motor Controller detected a UL Error condition related to a hardware failure.

Cause

- Software update needed
- Bad Motor Controller

Remedy

- Ensure that latest software is installed. Download the latest software <https://www.halo.fitness/web/softwareDownload.html>.
- Replace Motor Drive Board / Motor Controller

Error 77

Error Message Displayed to user

- E77

Condition

USB power is / was shorted.

Cause

- Android/USB micro cable shorted

Remedy

- Check USB dongle, cable, device for damage
- Replace USB dongle, cable, device

Error 78

Error Message Displayed to user

- E78
- Notify Maintenance Motor Controller Error (Motor Thermal Shutdown)

Keep error on screen until **OK** button pressed.

Condition

Error sent by Motor Controller if it detects the internal motor thermal / temperature switch tripped. This disables the motor until it cools down and the thermal switch re-engages.

Reset occurs when motor's internal winding temperature $< 102\text{ }^{\circ}\text{C} \pm 11\text{ }^{\circ}\text{C}$.

Cause

- Motor thermal cable damaged or has a loose connection.
- Worn Belt / Deck
- Excessive user weight
- Restricted airflow (clear area / vents)
- High room ambient temperature
- Bad motor

Remedy

- If the motor is cool and this error is occurring check the motor thermal cable for damage, measure with DMM for open.
- Legitimate error occurs when motor is overworked due to worn belt / deck, poor airflow, excessive use, debris entrapment etc.
- The motor's internal thermal switch tripped, disabling the motor. The motor's thermal switch opens when the motor temperature exceeds the switches trip point (thermal switch will close once motor cools down).
- This can be due to excessive user weight, restricted airflow, excessively hot environment. Clean around machine, make sure it is not near a heat source.
- The motor thermal sensor system (wires / connectors) should also be checked. If the thermal switch measures open when the motor is cool there is a problem in the wiring or the switch has failed.
- Replace Drive Motor
- Replace Motor Drive Board

Error 79

Error Message Displayed to user

- E79

Condition

The console lost communication with the keypad controller.

Cause

- Bad Keypad controller
- Bad cable to Keypad

Remedy

- Replace Keypad controller
- Replace cable to Keypad

Error 80

Error Message Displayed to user

- E80
- Notify Maintenance Brake Deactivated

Keep error on screen until **OK** button pressed.

Condition

Error sent by the Motor Controller when it detects that the mechanical brake was inadvertently disabled. Try to enable the mechanical brake. Check / replace the cable or fan / brake board.

Cause

- Check brake cable if unplugged or damaged
- Fan / Brake board is defective

Remedy

- Check brake switch function with a multimeter
- Check / reseal brake cable
- Repair / replace as needed

Error 81

Error Message Displayed to user

- E81
- Notify Maintenance RPM Limit Error

Keep error on screen until **OK** button pressed.

Condition

Error sent by Motor Controller when it has exceeded its internal RPM limit. A step speed too far from the target speed was detected due to excessive weight or abrupt non-typical operation.

Cause

- Excessive weight
- User jumping on or pushing down excessively hard on steps
- Steps momentarily jammed (but not long enough for error 90)

Remedy

- Check for entrapped debris, towels, etc., and remove
- Check encoder cable / connection to System Interface Board / PMC board, unseat and reseat cable
- Run encoder test
- Run encoder calibration
- Replace encoder
- Encoder misadjusted or damaged, cable damage
- Most known causes for this error are related to the way the user uses the equipment, if the error is not repeatable it may have been caused by the user jumping or pushing excessively hard on the steps

Error 82

Error Message Displayed to user

- E82
- Notify Maintenance!
Dump Resistor Error

Keep error on screen until **OK** button pressed.

Condition

Error sent by MC when the dump resistor maximum 'on-time' has been exceeded. Thus maximum allowed resistor power was dissipated for an excessive period.

Cause

- Excessive user weight at high speed
- Damaged bus dump resistor
- Wrong power resistor value

Remedy

- Check condition of dump resistor and resistor wiring. Repair / replace as needed.
- Check / measure value of dump resistor (100 Ohm). Replace as needed.
- Is error repeatable? Diagnose / replace MDB.
- If not repeatable error could have been caused by heavy / highspeed / extreme workout or temporary high input voltage.

Error 83

Error Message Displayed to user

- E83
- Notify Maintenance
Dump Resistor Test Error

Keep error on screen until **OK** button pressed.

Condition

Error sent by the Motor Controller when the dump resistor is not detected (i.e. test failed).

Cause

- Bus dump power resistor unplugged
- Bus dump power resistor damaged. Replace.
- Bad MDB

Remedy

- Check / reseal dump resistor wiring. Repair / replace as needed.
- Check / measure dump resistor (100 Ohm). Replace / replace as needed.
- Diagnose / replace MDB.

Error 84

Error Message Displayed to user

- E84
- Notify Maintenance
RPM Sensor Error

Keep error on screen until **OK** button pressed.

Condition

Error sent by Motor Controller when the encoder RPM difference test has detected a significant and unexpected change.

Cause

- Encoder mounting issue
- Bad Encoder

Remedy

- MDB or motor phase loss
- Extreme use

Error 89

Error Message Displayed to user

- E89
- Notify Maintenance Bus Dump Power Error

Keep error on screen until **OK** button pressed.

Condition

Motor Controller reporting a Bus Dump resistor power to stop error. Maximum allowed resistor power was dissipated for an excessive time period stopping the machine.

Cause

- Verify bus dump resistor value
- Damaged bus dump resistor
- High Input voltage
- Bad Motor Drive Board
- Excessive user weight, at high speed

Remedy

- Check condition of dump resistor and resistor wiring. Repair / replace as needed.
- Check / measure value of dump resistor (100 Ohm). Replace as needed.
- Is error repeatable? Diagnose / replace Motor Drive Board.
- If not repeatable error could have been caused by heavy / high speed / extreme workout or temporary high input voltage.

Error 90

Error Message Displayed to user

- E90
- Notify Maintenance Steps Jammed

Keep error on screen until **OK** button pressed.

Condition

Maximum positive force exceeded error, as reported by Motor Controller. The drive system detected having to push the steps excessively to maintain speed.

Cause

- Check for something jamming the steps.

Remedy

- Check for and remove entrapped objects by pushing steps backward by hand within 45 seconds of the jam. Restarting the steps will reactivate the 45 sec un-jam period until cleared.
- Check for excessive step drag. Diagnose / repair as needed.
- Check motor wiring and phase continuity. Repair / replace as needed.

Error 91

Error Message Displayed to user

- E91
- Notify Maintenance Mechanical Brake Error

Keep error on screen until **OK** button pressed.

Condition

Error sent by the Motor Controller when it detects the mechanical brake has failed which is detected when the Motor Controller has the brake locked but RPM's / movement is detected and it shouldn't be.

Cause

- Jammed mechanical Brake
- Worn mechanical brake
- Cable
- Motor Controller
- Encoder

Remedy

- Check / reseal brake cable. Repair / replace as needed.
- Check for brake jamming or slippage. Repair / replace as needed.
- Check brake and encoder securement to shaft. Repair / replace as needed.
- Check encoder for damage. Replace as needed.
- Replace Motor Drive Board

Error 93

Error Message Displayed to user

- E93

Condition

The RMS current drawn by the motor was excessive causing a step slowdown.

Cause

- Bad motor / wiring
- Bad Motor Controller
- Excessive user weight
- Jumping / pushing on steps

Remedy

- Check motor and motor cabling for damage. Repair / replace as needed.
- Is error repeatable? Check Motor Drive Board. If not repeatable, may have been due to user jumping on or pushing steps.
- PowerMills can exceed current while trying to slow a user down. Could be caused by manner of use or user characteristics.

Error 94

Error Message Displayed to user

- E94
- Notify Maintenance No Motor Current

Keep error on screen until **OK** button pressed.

Condition

No Motor Current measured

Cause

- Motor might be unplugged from Motor Controller board
- Bad Motor Controller

Remedy

- Check to verify motor is plugged into Motor Drive Board / Motor Controller board.
- Check motor and motor cabling for damage. Repair / replace as needed.
- Check motor phase continuity
- Replace Motor Drive Board / Motor Controller

Error 101

Error Message Displayed to user

E101

Condition

Unable to communicate with LifePulse Module.

Cause

- No LifePulse board
- LifePulse board un-programmed
- LifePulse connector P7 damaged

Remedy

- Replace LifePulse board
- Replace Fitcore board
- Replace console

Error 110

Error Message Displayed to user

E110

Condition

LifePulse Module firmware update failed.

Cause

- Update image is corrupted
- Intermittent connection issues
- Damaged LifePulse module

Remedy

- Re-download software update, retry software update
- Check condition and connections of LifePulse cable, un-seat and re-seat connections, retry software update
- Replace LifePulse board
- Replace console

Error 120

Error Message Displayed to user

E120

Condition

ECB calibration ended in failure.

Cause

- Software bug
- Motor(s) not moving
- Failed limit switch(es)
- Move timed out (took too long)

Remedy

- Ensure that latest software is installed. Download the latest software <https://www.halo.fitness/web/softwareDownload.html>.
- Cycle power / reboot
- Check cabling, connectors and terminals for M2 and M3, are motors connected to ECB?
- Do motors move?
 - No - 1) Replace ECB, 2) Replace motor
 - Yes - Verify limit switches functional (open when engaged) and properly positioned.
- Make sure actuators / linkage are free to move, not jammed in any way, excessive motor load can cause this error.

Error 121

Error Message Displayed to user

E121

Condition

M2 stride position sensing error.

Cause

- Bad cables and connectors
- Bad ECB or motor
- Failed limit switch(es)

Remedy

- Check cabling and connections
- Do motors move?
 - No - 1) Replace ECB, 2) Replace motor
 - Yes - Verify limit switches functional (open when engaged) and properly positioned.
- If motor is turning and position error is occurring there must be a problem with feedback signal or detection circuit.
- Test - swap M2 and M3 connectors at ECB, re-power equipment, if new error 121 occurs - problem with ECB, if error 122 occurs - problem with motor / encoder.
- To check M2 feedback measure ECB P5 pin 6(+) to pin 5(-) as motor moves 5V should toggle up and down.

Error 122

Error Message Displayed to user

E122

Condition

M3 stride position sensing error.

Cause

- Bad cables and connectors
- Bad ECB or motor
- Failed limit switch(es)

Remedy

- Check cabling and connections.
- Do motors move?
 - No - 1) Replace ECB, 2) Replace motor.
 - Yes - Verify limit switches functional and properly positioned.
- If motor is turning and position error is occurring there must be a problem with feedback signal or detection circuit.
- Test - swap M2 and M3 connectors at ECB, re-power equipment, if new error 122 occurs - problem with ECB, if error 121 occurs - problem with motor / encoder.
- To check M3 feedback measure ECB P4 pin 6(+) to pin 5(-) as motor moves 5V should toggle up and down.

Error 123

Error Message Displayed to user

E123

Condition

M1 resistance position sensing error.

Cause

- Bad cables and connectors
- Bad motor
- Bad potentiometer

Remedy

- Check cabling and connections
- Do motors move? If motor is turning and error is occurring there must be a problem with feedback signal or detection circuit.
- Measure potentiometer resistance, move motor, re-measure potentiometer resistance, if no change potentiometer signal bad.

Error 124

Error Message Displayed to user

E124

Condition

ECB base - 5V power supply short detection

Cause

- Damaged wiring to M1, M2 and/or M3
- Low Vext
- Bad Vext brick power supply
- Bad ECB

Remedy

- Check wiring to M1, M2 and M3 for damage. Repair / replace as needed.
- Measure Vext to ensure rated V output
- Replace ECB

Error 125

Error Message Displayed to user

E125

Condition

ECB base - Verp power supply short detection.

Cause

- Damaged console and / or ErP wiring
- Low Vext
- Bad Vext brick power supply
- Bad ECB

Remedy

- Check wiring between ECB and console for damage. Repair / replace as needed.
- Check ErP wiring/components Repair / replace as needed
- Measure Vext to ensure rated V output
- Replace ECB

Error 126

Error Message Displayed to user

E126

Condition

ECB base - Vsys power supply short detection.

Cause

- Damaged console wiring
- Damaged console
- Bad Vext brick power supply
- Bad ECB

Remedy

- Check wiring between ECB and console for damage. Repair / replace as needed.
- Measure Vext to ensure rated V output. If Vsys < 7V console may be drawing too much current - may need to diagnose console.
- Replace ECB.

Error 127

Error Message Displayed to user

E127

Condition

ECB and RCB base - Vsys power supply over voltage detection.

Cause

- Bad Vext brick power supply
- Bad ECB

Remedy

- Measure Vext to ensure rated V output. Vsys too high, replace brick power supply.
- Replace ECB

Error 128

Error Message Displayed to user

E128

Condition

M2 actuator diagnostic run ended in failure.

Cause

- Bad cables and connectors

Remedy

- Check cables and connections.
- Unseat and re-seat connector.

Error 129

Error Message Displayed to user

E129

Condition

M3 actuator diagnostic run ended in failure.

Cause

- Bad cables and connectors

Remedy

- Check cables and connections.
- Unseat and re-seat connector.

Error 131

Error Message Displayed to user

E131

Condition

M2 actuator disconnected.

Cause

- Bad cables and connectors
- Bad ECB
- Bad actuator

Remedy

- Any power to actuator? No, check cable and connections / terminals to actuator.
- Swap M2 and M3 be connections at ECB: Does problem follow ECB output terminal, actuator or neither?
 - If problem follows terminal, replace ECB.
 - If problem follows actuator, replace actuator
 - If neither it may be intermittent connection.
- Replace ECB / actuator as needed.

Error 132

Error Message Displayed to user

E132

Condition

M3 actuator disconnected.

Cause

- Bad cables and connectors
- Bad ECB
- Bad actuator

Remedy

- Any power to actuator? No, check cable and connections / terminals to actuator.
- Swap M2 and M3 be connections at ECB: Does problem follow ECB output terminal, actuator or neither?
 - If problem follows terminal, replace ECB.
 - If problem follows actuator, replace actuator
 - If neither it may be intermittent connection.
- Replace ECB / actuator as needed.

Error 135

Error Message Displayed to user

E135

Condition

M2 travel error, indicates that when calibrating, the stride motors did not activate the home switch in their allotted time.

Cause

- Bad cables and connectors
- Bad home switch
- Bad ECB
- Bad actuator

Remedy

- Is motor moving?
- Is motor engaging home switch?
- Does home switch measure open when in home position?
- Does the home switch open/close when position changes?

In addition, see [Error 131](#), [Error 132](#) for additional troubleshooting.

Error 136

Error Message Displayed to user

E136

Condition

M3 travel error, indicates that when calibrating, the stride motors did not activate the home switch in their allotted time.

Cause

- Bad cables and connectors
- Bad home switch
- Bad ECB
- Bad actuator

Remedy

- Is motor moving?
- Is motor engaging home switch?
- Does home switch measure open when in home position?
- Does the home switch open/close when position changes?

In addition, see [Error 131](#), [Error 132](#) for additional troubleshooting.

Error 137

Error Message Displayed to user

E137

Condition

Stride Sensor is not connected on Tread Base.

Cause

- Certain models that may not have stride sensor hardware installed
- Sensor not plug-in properly

Remedy

- Ensure Stride sensor is connected and cable / terminals in good condition

Error 138

Error Message Displayed to user

E138

Condition

Error 138 occurs after a software update.

Cause

- Failed firmware update attempt (majority of the time)
- Corrupted firmware
- Board failure

Remedy

- Ensure that latest software is installed. Download the latest software <https://www.halo.fitness/web/softwareDownload.html>.
- Repeating the software update should clear the error.

NOTE: The software update may take 3 to 4 attempts to successfully clear the error.

- Replace base board

Error 141

Error Message Displayed to user

E141

Condition

Touch Screen Calibration Started

Cause

- This is not an error, it is simply a way to log that touch screen calibration has begun.

Remedy

- None

Error 142

Error Message Displayed to user

E142

Condition

Touch Screen Calibration Accepted

Cause

- This is not an error, it is simply a way to log that touch screen calibration has been accepted.

Remedy

- None

Error 143

Error Message Displayed to user

E143

Condition

Data Resolver Update

Cause

Replacement of a console or base printed circuit board

Remedy

- Error 143 indicates that an update is taking place to resynchronize the persistent data. Allow adequate time for completion of the update and associated reboot
- If the problem persists try reprogramming the sku and model number: This can be done on Integrity X console by using the **System Options > Manufacturer Settings**
- On Integrity C and Cybex 50L consoles a USB SKU Programming must occur

Error 148

Error Message Displayed to user

E148

Condition

CSN doesn't contain console type.

Cause

When the SKU manager can't determine the Console Type from the CSN.

Remedy

- Replace the console
- Return the console for correct console serial number reprogramming (reprogramming is not possible in the field as it requires a serial debug connection)

Error 149

Error Message Displayed to user

E149

Condition

SKU doesn't contain product type.

Cause

When the SKU manager can not determine the Product Type from the SKU.

Remedy

- Program correct base SKU
- This can be done on Integrity X console by using the **System Options > Manufacturer Settings**
- On Integrity C and Cybex 50L consoles a USB SKU Programming must occur

Error 151

Error Message Displayed to user

E151

Condition

Console **GO / STOP / PAUSE** key not detected

Cause

Console **GO / STOP / PAUSE** keypad disconnected.

Remedy

- Insure all connectors are connected properly (Specifically P13 and P14). P13 is connector for console-front **GO / STOP / PAUSE** keys. Unseat / reseal connectors
- On PowerMill remote bullhorn bars have **STOP** key which is plugged into P14 and P22. Those must be plugged in as well for that unit type.

Error 152

Error Message Displayed to user

E152

Condition

Media keypad not detected

Cause

- Non-entertainment SKU
- Media keypad disconnected

Remedy

- For all non-entertainment SKU's this error may occur once on every boot, ignore error.
- Ensure console code is up to date (outdated code may pop-up message on [LED](#) or [LCD](#) screen - no pop-up with current code.
- If equipment has TV or MYE receiver:
 1. Ensure that the media keypad is connected to the Fitcore board.
 2. Replace the media keypad and / or cable.

Error 153

Error Message Displayed to user

E153

Condition

Base data remapped console to reboot soon

Cause

- Integrity C, X or Cybex 50L console. Data stored in the base is being upgraded.
- This is not a fatal error. The process will take between a few seconds and as long as a minute.

Remedy

- Error 153 indicates that an update is taking place to synchronize the persistent data when a software update is being performed. Allow adequate time for completion of the update and associated reboot.
- If the problem persists try reprogramming the SKU and model number: This can be done on Integrity X console by using the **System Options > Manufacturer Settings**.
- On Integrity C and Cybex 50L consoles a USB SKU Programming must occur.
- See Service Bulletin EC180109 and / or Knowledge Base Article 2522.

Error 155

Error Message Displayed to user

E155

Condition

Console Serial Number is missing.

Cause

- The Console was manufactured without a Serial Number

Remedy

- Replace the console
- Return the console for correct console serial number reprogramming. Reprogramming is not possible in the field as it requires a serial debug connection

See [Error 20](#), [Error 148](#).

Error 157

Error Message Displayed to user

E157

Condition

Base Serial Number is missing.

Cause

- The unit serial number is not present to be read from the base.

Remedy

- Reprogram base serial number:

Error 601

Error Message Displayed to user

E601

Condition

Wireless connectivity DHCP Failure

Cause

- Wireless connectivity failed to provide DHCP

Remedy

- Most likely the router / access point is not properly configured to provide DHCP support, check router settings.
- Try power cycling equipment.

Error 602

Error Message Displayed to user

E602

Condition

Wireless connectivity Authentication Failure

Cause

- Authentication Failed verify Credentials.

Remedy

- The most likely cause for this error is that the wireless router password for the **LFwireless** SSID is incorrect, re-enter password

10. Schematics

Online References

Detailed Schematics are available online in Parts Manuals:

- <https://www.lftechsupport.com> access technical documentation and part manuals for Life Fitness, Hammer Strength, and ICG.
- <http://www.lifefitness.com/parts> service parts ordering for Life Fitness, Cybex, SCIFIT, Hammer Strength, and ICG products along with warranty parts ordering and technician requests.
- <https://lfworld.lifefitness.com> easy to find Knowledge Base articles with answers to frequently asked questions and product support documentation for Life Fitness, Cybex, SCIFIT, Hammer Strength, and ICG.

11. Glossary

Connectors

Electrical plugs used to connect wiring into electrical component.

LCD

Liquid Crystal Display - Thin, flat electronic visual display that uses the light modulating properties of liquid crystals.

LED

Light Emitting Diode - LED's provide display functionality and are commonly used for indicator lights.

Lifepulse™

Life Fitness' proprietary hardware and software system designed to measure user's heart rate by making electrical contact at user's palms.

MDB

Motor Drive Board

MIB

Maintenance Interface Board

NFC

Near Field Communication is a set of short-range wireless technologies, typically requiring a distance of 4cm or less to initiate a connection. NFC allows you to share small payloads of data between an NFC tag and an Android-powered device, or between two Android-powered devices.

PCB

Power Control Board - Regulates voltage to alternator, console, and battery.

SIB

System Interface Board

12. Warranty

What is Covered

This *Life Fitness* commercial exercise equipment product is warranted to be free of all defects in material and workmanship.

Who is Covered

The original purchaser or any person receiving the product as a gift from the original purchaser. Warranty will be voided on subsequent transfers.

How Long It is Covered

All coverage is provided by specific Product according to the guidelines listed in Warranty Information.

Who Pays Transportation and Insurance For Service

If the Product or any covered part must be returned to a service facility for repairs, We, *Life Fitness*, will pay all transportation and insurance charges for the first year. You are responsible for transportation and insurance charge after the first year.

What We Will Do To Correct Covered Defects

We will ship to you any new or rebuilt replacement part or component, or at our option, replace the Product. Such replacement parts are warranted for the remaining portion of the original warranty period.

What is Not Covered

Any failures or damage caused by unauthorized service, misuse, accident, negligence, improper assembly or installation, debris resulting from any construction activities in the Product's environment, rust or corrosion as a result of the Product's location, alterations or modifications without our written authorization or by failure on your part to use, operate and maintain the Product as set out in your Operation Manual ("Manual").

One type RJ45 interchangeable Network ready and Fitness Entertainment port is supplied with the Product. This port complies with the FitLinxx CSAFE specification dated August 4, 2004 stating: 4.75VDC to 10VDC; maximum current of 85mA. Any Product damage caused by a load exceeding this FitLinxx CSAFE specification is not covered by warranty.

All terms of this warranty are void if this product is moved beyond the continental borders of the United States of America (excluding Alaska, Hawaii and Canada) and are then subject to the terms provided by that country's local authorized *Life Fitness* representative.

What You Must Do

Retain proof of purchase. use, operate and maintain the Product as specified in the Manual; notify the place of purchase of any defect within 10 days after discovery of the defect; if instructed, return any defective part for replacement or, if necessary, the entire Product for repair. *Life Fitness* reserves the right to decide whether or not a product is to be returned for repair.

How to Get Parts and Service

Refer to the Corporate Headquarters section of this manual for your local service contact information. Reference your name, address and the serial number of your Product (consoles and frames may have different serial numbers). They will tell you how to get a replacement part, or, if necessary, arrange for service where your Product is located.

Exclusive Warranty

THIS LIMITED WARRANTY IS IN LIEU OF ALL OTHER WARRANTIES OF ANY KIND EITHER EXPRESSED OR IMPLIED, INCLUDING BUT NOT LIMITED TO THE IMPLIED WARRANTIES OF MERCHANTABILITY AND FITNESS FOR A PARTICULAR PURPOSE, AND ALL OTHER OBLIGATIONS OR LIABILITIES ON OUR PART. We neither assume nor authorize any person to assure for us any other obligation or liability concerning the sale of this Product. Under no circumstances shall we be liable under this warranty, or otherwise, of any damage to any person or property, including any lost profits or lost savings, for any special, indirect, secondary, incidental or consequential damages of any nature arising out of the use of or inability to use this Product. Some states do not allow the exclusion or limitation of implied warranties or of liability for incidental or consequential damages, so the above limitations or exclusions may not apply to you.

Changes in Warranty Not Authorized

No one is authorized to change, modify or extend the terms of this limited warranty.

Effects of State Laws

This warranty gives you specific legal rights, and you may have other rights which vary from state to state and country by country.

Warranty Information

	Lifetime	10 years	7 years	3 years	2 years	1 Year	6 Months
Commercial Console					Electrical and Mechanical Parts	Labor	Overlay, Headphone Jack, and USB Port
Treadmill (95T, INTSX, INTDX)			Frame, Lifespring™ Shock Absorbers, and Motor		Electrical Components	Mechanical Components and Labor	
Treadmill (PCST)	Motor and Frame	Electrical and Mechanical Parts				Labor	
Treadmill Club Series +	Motor and Frame	Electrical and Mechanical Parts				Labor	
Cross-Trainer (95X)					Electrical and Mechanical Parts	Labor	
Cross-Trainer (PCSX)	Frame			Electrical and Mechanical Parts		Labor	
Cross-Trainer (Club Series +)				Electrical and Mechanical Parts		Labor	
Cross-Trainer (INXDX, INXSX)					Electrical and Mechanical Parts	Labor	
Recumbent Bike (95R)					Electrical and Mechanical Parts	Labor	
Recumbent Bike (PCSR)	Frame			Electrical and Mechanical Parts		Labor	
Recumbent Bike (Club Series +)				Electrical and Mechanical Parts		Labor	
Recumbent Bike (INRDX, INRSX)					Electrical and Mechanical Parts	Labor	
Upright Bike (95C)					Electrical and Mechanical Parts	Labor	
Upright Bike (PCSC)	Frame			Electrical and Mechanical Parts		Labor	

	Lifetime	10 years	7 years	3 years	2 years	1 Year	6 Months
Upright Bike (Club Series +)				Electrical and Mechanical Parts		Labor	
Upright Bike (INCDX, INCSX)					Electrical and Mechanical Parts	Labor	
FlexStrider (95FS)					Electrical and Mechanical Parts	Labor	
PowerMill (95PS)					Electrical and Mechanical Parts	Labor	
Arc Trainer					Electrical and Mechanical Parts	Labor	

Warranties outside the U.S. may vary.

